



# Open Base Flat Top Work Table

*Stainless Steel Work Tables*



Use your smart phone to scan the above QR code to visit our website:  
www.bk-resources.com

## Certifications:



## Features:

- 1 5/8" Legs
- Legs Adjust 1" in Height
- Ships KD
- Two Sound Deadened Integrally Welded 5" C Channels to Reinforce & Maintain Level Working Surface
- 96" & 84" Tables Have 6 Legs

## Options:

- Single & Double Overshelves
- Drawer Assemblies
- Casters
- Adjustable Table Mount Pot Rack



## Material:

- T-304 14 ga. Stainless Steel Top
- Stainless Steel Legs & Bracing
- 1 1/4" Adjustable Stainless Steel Feet
- Capacity: 1,200 lbs Evenly Distributed

Part #	Length	Width
QVTR50B-2424	24"	24"
QVTR50B-3024	30"	24"
QVTR50B-3624	36"	24"
QVTR50B-4824	48"	24"
QVTR50B-6024	60"	24"
QVTR50B-7224	72"	24"
QVTR50B-8424	84"	24"
QVTR50B-9624	96"	24"
QVTR50B-3030	30"	30"
QVTR50B-3630	36"	30"
QVTR50B-4830	48"	30"
QVTR50B-6030	60"	30"
QVTR50B-7230	72"	30"
QVTR50B-8430	84"	30"
QVTR50B-9630	96"	30"

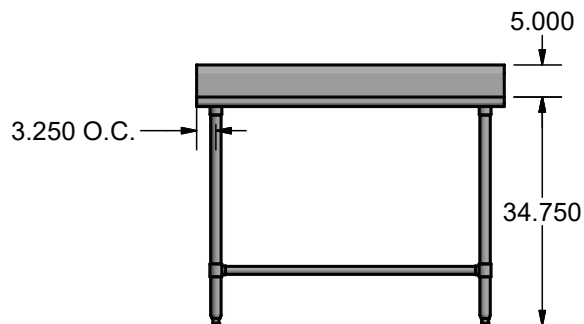
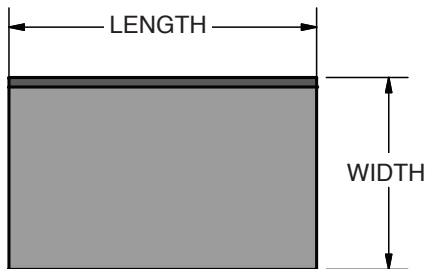
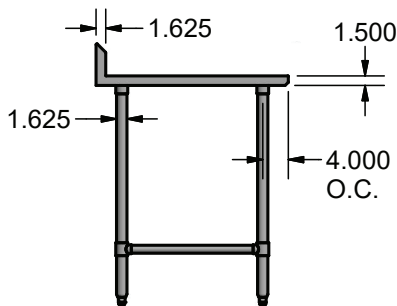

1.250 Adjustable Stainless Steel Feet

PRODUCT DATA SHEET

BK RESOURCES

