



# REACH-IN

## DOUBLE DOOR REFRIGERATOR MODEL RS2R-52-2

The Model RS2R-52-2 represents Randell's *Specification Series* reach-ins in a dual section refrigerator. The single compressor system is designed to meet the latest DOE energy standards and is balanced with the highest quality components and controls to provide exceptional performance for the operator.

### STANDARD FEATURES:

- Energy efficient single compressor system
- Digital controls
- Integrated door alarm
- Automatic adaptive defrost system
- Efficient hot gas condensate evaporator
- LED interior lighting
- Adjustable, heavy duty, stainless steel wire shelves
- 9' cord and plug
- Door locks
- 5" casters (front two locking)
- Door pressure relief valve

### CABINET CONSTRUCTION:

- Exterior Front: Stainless Steel
- Exterior Sides: Stainless Steel
- Exterior Body: Galvanized Steel
- Interior Sides: Stainless Steel
- Interior Floor: Stainless Steel

Insulation is foamed in place high density polyurethane (CFC free). Units provided with (6) adjustable, heavy duty, stainless steel wire shelves. Unit is provided with 5" casters (field installed) are affixed to bottom of unit.

### DOORS:

- Exterior: Stainless Steel
- Interior: Stainless Steel

Doors are self-closing with heavy duty cam lift hinges. The doors stay open after 90 degrees for easy loading. Doors include easily replaceable one-piece magnetic gaskets. Cabinet is provided with door pressure relief device to assist in easy opening of the doors. Interior is illuminated with door activated, energy efficient LED lighting.

**REFRIGERATION SYSTEM:** Self-contained compressor refrigeration system using R-290 is balanced to regulate top mounted evaporator coil providing superior air circulation to the storage compartment. Top-mounted compressor design provides easier access for preventative maintenance, condenser cleanings and accumulates less dirt than bottom-mount compressors. Condensate is evaporated by a rear mounted hot gas system that has protective coating on hot gas loop for extended life. Refrigerator is designed to operate between 33°F and 38°F. Standard settings are easily managed by simple up/down arrows. The controller includes an audible alarm which produces three low-volume beeps after the door is open for thirty seconds.

**ELECTRICAL:** Unit comes from the factory prewired with a 9ft. cord and plug and ready for plugging into a dedicated 115/60/1 phase, 15-amp outlet.

PROJECT NAME:

LOCATION:

ITEM NO:

QTY:

MODEL NO:

AIA NO:

SIS NO:

CSI SECTION: 11400



### OPTIONS/ACCESSORIES:

- Extra interior shelves

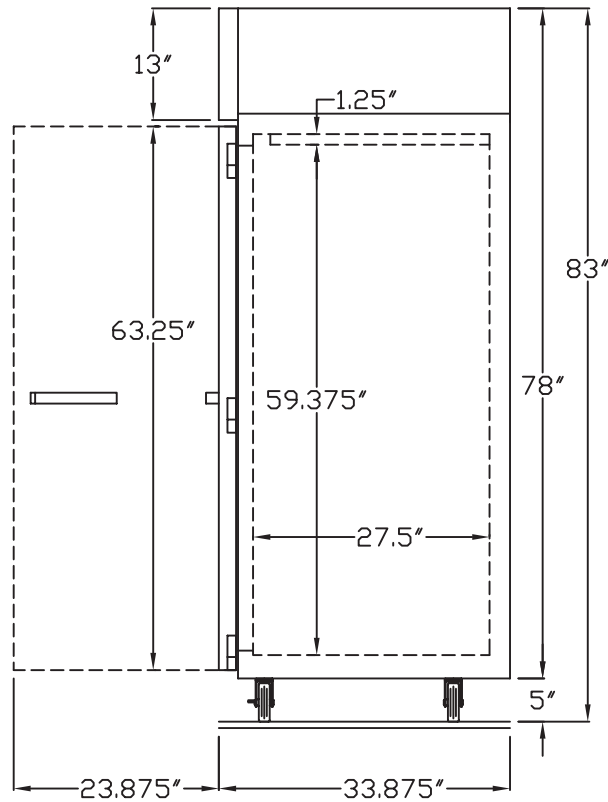
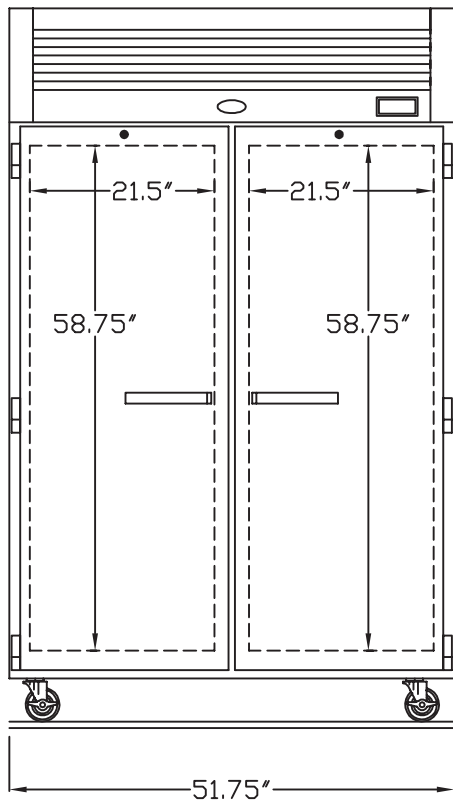
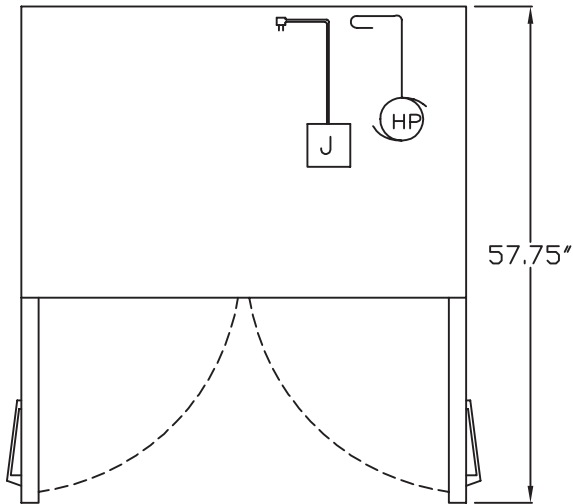

Model	Hinged	L	D	H	Doors	Storage Cu. Ft.	Shelves	HP	Power	Amps	NEMA	Ship Wt.
RS2R-52-2	Left/Right	51.75"	33.875"	83"	2	43.4	6	2/3	115/60/1	4	5-15P	538