



Project:

Item Number:

Quantity:

Modular Drop-in: NSF7 Refrigerated Cold Pans

The Vollrath Company, L.L.C.

MODULAR DROP-IN: NSF7 REFRIGERATED COLD PANS



Modular Drop-In: NSF7 Refrigerated Cold Pans

DESCRIPTION

The modular drop-in NSF7 refrigerated cold pans are designed for top-mount installation.

A full-perimeter drip edge contains spills and condensation within the stainless steel countertop area of the drop-in.

High-density polyurethane foam insulation surrounds the exterior of the well to provide most efficient performance with energy savings.

A 3" (7.6 cm) recess lowers the food pan below the work surface to minimize the impact of ambient air. The deep display well is designed to accommodate standard 12" x 20" (30.4 cm x 50.8 cm) pans up to 6" (15.2 cm) deep.

Refrigeration coils surround the exterior side walls of well for maximum cooling. Refrigerant is R134A to meet federal standards.

Cold drop-ins are best used for holding periods up to four hours. For best performance, stainless steel containers are recommended.

Modular drop-in orders cannot be canceled or returned.

Agency Certifications



Due to continued product improvement, please consult www.vollrathco.com for current product specifications.

MODELS

- 36456 One Pan
- 36429 Two Pan
- 36430 Three Pan
- 36434 Four Pan
- 36436 Five Pan
- 36438 Six Pan

FEATURES

- Top is 18-gauge stainless steel, 18-8 Type 304, with 3/8" (9.52 mm) overhang on all sides and die stamped with full-perimeter drip edge. Molded breaker gasket fitted under drip edge.
- Flat work surface around opening.
- Seamless well is 18-gauge 18-8 stainless Type 304, 6 5/8" (16.8 cm) deep.
- 1" (2.5 cm) integral drain is standard.
- Refrigeration coils surround exterior side walls of well.
- Inner well assembly insulated with foamed in place polyurethane foam insulation.
- Condensing unit suspended below well.
- Temperature control on compressor.
- For complete air circulation, two openings in the cabinet are required. Louver cutout size is 8" x 10" (20.3 cm x 25.4 cm).
- Exterior housing is 18-gauge galvanized steel.
- Optional perforated false bottom is nominal 1" (2.5 cm) high and constructed of 18-gauge Type 304 stainless steel. False bottom will reduce pan depth by same dimension. False bottom options:

Drop-In Model	False Bottom Model
36456	70100
36429	36913
36430	36914
36434	36915
36436	36916
36438	36917

- Unit comes with cord and plug and does not require hard wiring.
- On/Off switch is mounted on side of compressor housing.
- Positioning clips provided to center drop-in within cutout.
- One year parts and labor warranty. Additional four years on compressor.

WARRANTY: All models shown come with Vollrath's standard warranty against defects in materials and workmanship. For full warranty details, please refer to the Vollrath Equipment and Smallwares Catalog.

Approvals	Date



Setting the Standard™

www.vollrathco.com

The Vollrath Company, L.L.C.
1236 North 18th Street
Sheboygan, WI 53081-3201 U.S.A.
Customer Service: 800.628.0830
Canada Customer Service: 800.695.8560
Main Fax: 800.752.5620 or 920.459.6573

Technical Services: 800.628.0832
Technical Services Fax: 920.459.5462

A City Discount

MODULAR DROP-IN: NSF7 REFRIGERATED COLD PANS

MODELS	36456 One Pan	36434 Four Pan
	36429 Two Pan	36436 Five Pan
	36430 Three Pan	36438 Six Pan

DIMENSIONS

- ❑ **NOTE: Opening cutout must have a 7/8" (2.2 cm) corner radius.**
- ❑ Dimensions shown in inches (cm)

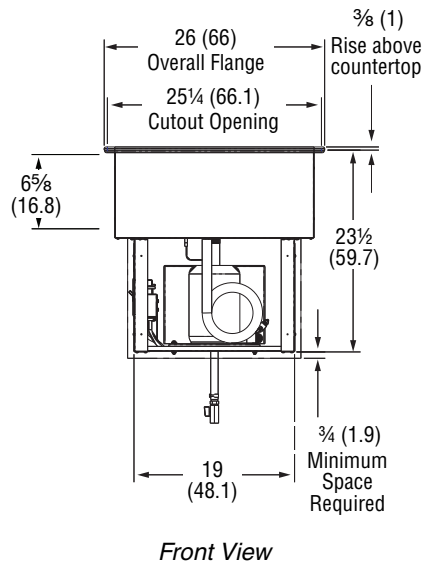
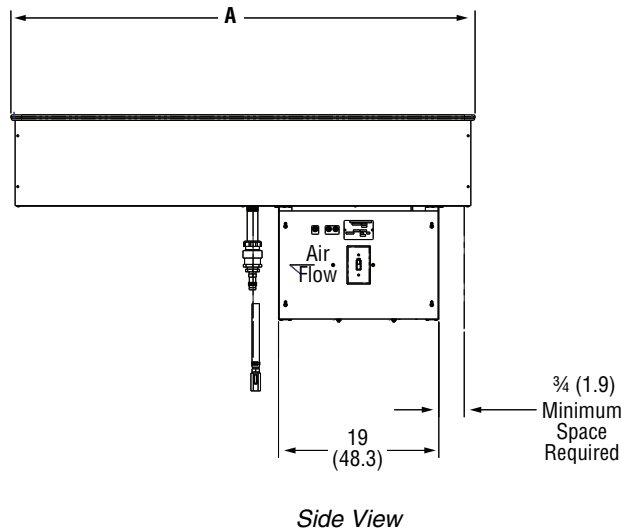
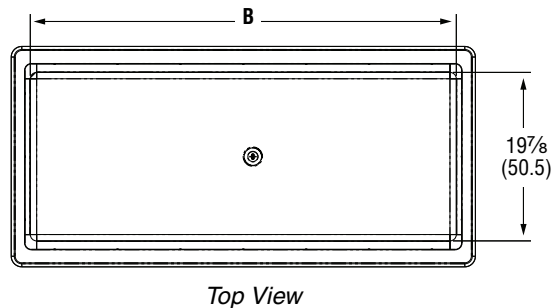

SPECIFICATIONS

Item	(A) Overall Length	(B) Display Length	Cutout		Compressor	Voltage	Amps	Plug
			Length	Width				
36456	18 (45.7)	12 (30.5)	17 1/4 (43.8)	25 1/4 (64.1)	1/4 HP	120	3.8	5-15P
36429	29 (73.6)	24 3/4 (62.9)	28 1/4 (71.8)	25 1/4 (64.1)	1/4 HP	120	4.9	5-15P
36430	41 1/2 (105.4)	37 1/2 (95.3)	40 3/4 (103.5)	25 1/4 (64.1)	1/4 HP	120	4.9	5-15P
36434	54 3/4 (139.1)	50 1/4 (127.6)	54 (137.2)	25 1/4 (64.1)	1/3 HP	120	7.2	5-15P
36436	68 (172.7)	63 (160)	67 1/4 (170.8)	25 1/4 (64.1)	1/2 HP	120	11	5-20P
36438	81 1/4 (206.4)	75 3/4 (192.4)	80 1/2 (204.5)	25 1/4 (64.1)	1/2 HP	120	11	5-20P

Receptacles

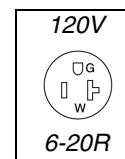
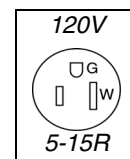

www.vollrathco.com

The Vollrath Company, L.L.C.
 1236 North 18th Street
 Sheboygan, WI 53081-3201 U.S.A.
 Customer Service: 800.628.0830
 Canada Customer Service: 800.695.8560
 Main Fax: 800.752.5620 or 920.459.6573

Technical Services: 800.628.0832
 Technical Services Fax: 920.459.5462