

Refrigeration X

We Build Trust, Sell Satisfaction

4184 E. Conant St., Long Beach, CA 90808

www.RefrigerationX.com

Project:	
Model #:	
Item #:	
Available W/H:	Qty:
Approval:	
AIA #:	SIS #:
CSI Section 11400	

Sandwich / Salad Unit

Food Prep Tables
X-line

Model : XST-72-N



FEATURES & BENEFITS

Hydrocarbon refrigerants (R-290)

With innovative and eco-friendly technology, RefrigerationX brings you hydrocarbon refrigerators designed to meet DOE's Energy Conservation Standards in 2017 and to use EPA's SNAP Program approved HC refrigerants. Hydrocarbon refrigerants do not deplete the ozone layer and have very low contribution to global warming (ODP-0, GWP-3).

Cold air compartment

Our innovative "Cold Air Compartment" maintains temperature evenly for each pan to preserve fresh food longer. In addition, the compartment isolates pans from the reach-in area to prevent food spillage.

Cabinet construction

X-line model boasts a stainless steel exterior (door) with AL exterior sides (galvanized steel back and bottom). Interior is stainless steel floor and back with AL sides. It guarantees the utmost in cleanliness and long product life.

High-density polyurethane insulation

The entire cabinet structure and solid doors are foamed-in-place using high density, CFC free polyurethane insulation.

Convenient cutting board side rail

Self-contained system

4" dia. swivel casters with locks on the front set

1/6 size, 4" deep condiment pans included

9-1/2" deep, 1/2" thick cutting board included

Adjustable, heavy duty, PE (polyethylene) coated wire shelves

Refrigerator holds 33°F ~ 39°F for the best in food preservation

NATURAL Refrigerant

ETL Intertek

ETL Intertek

2 YEAR WARRANTY

5 YEAR WARRANTY

Model	Swing Doors	CU./FT.	#of Shelves	#of Pans	#of Hood	HP	AMPS	Crated Weight (lbs.)	L x D* x H† (inches)
XST-72-N	3	19	3	18	2	3/8	5.5	374	72 ³ / ₄ x 30 x 37 ¹ / ₂

Model : XST-72-N

ELECTRICAL DATA	
Voltage	115/60/1
Plug Type	 NEMA 5-15P
Full Load Amperes	5.5
Compressor HP	3/8
Cord Length (ft.)	9
Refrigerant	R-290
DIMENSIONAL DATA	
Net Capacity (cu. ft.)	19
Ext. Length Overall (in.)	72 ³ / ₄ (1847mm)
Ext. Depth Overall (in.)*	30 (764mm)
Ext. Height Overall (in.)†	37 ¹ / ₂ (952mm)
# of Doors	3
# of Shelves	3
Shelf Size (L x D) (in.)	21 x 16 ⁷ / ₈ (L/R), 22 ⁷ / ₈ x 16 ⁷ / ₈ (M)
Net Weight (lbs.)	330
Gross Weight (lbs.)	374

Design and specifications subject to change without notice.

Actual shipping weight may differ due to extra packing materials for product protection.

* Depth does not include 1-1/4" for rear spacers.

† Height does not include 4-3/4" for caster height.

■ WARRANTY : 2 Year Parts and Labor Warranty Additional 3 Year Warranty on Compressor

■ OPTIONAL ACCESSORIES

- 1" caster, 1/2" diameter & 13 TPI: S28R813660 (non-brake)
- 2.5" caster, 1/2" diameter & 13 TPI: 30265H0100 (non-brake), 30265H0200 (w/ brake)
- 5" caster, 1/2" diameter & 13 TPI: M726500100 (non-brake), M726500200 (w/ brake)
- Leveling leg, 1/2" - 13 TPI x 1.54": LFM1213566
- 6" ABS plastic leg: 30221M0200
- 6" stainless steel leg: 30221M0600
- Additional stainless steel shelf: WM77800100 (Left/Right), WM77800300 (Middle)
- Removable food cover: XR-RCT-72-L (L) / RX-RCT-72-R (R)
- Clear lid: RX-CL-72
- Single overshelf, stainless steel, 72-13/16" W: RX-TSOS-6S
- Double overshelf, stainless steel, 72-3/4" W: RX-TSOS-6R-T

PLAN VIEW

(unit : inch)

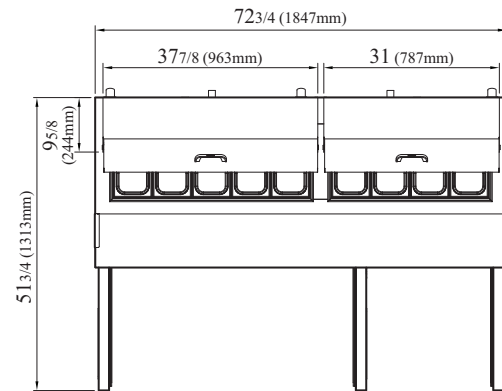

TOP VIEW

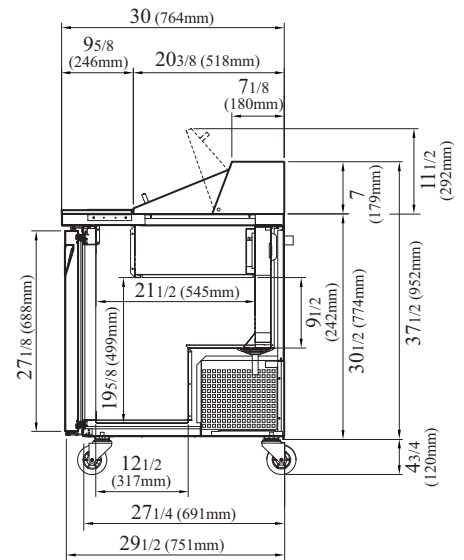

SIDE VIEW

Ver.20250108



Warranty : 800-381-7770
Warranty@RefrigerationX.com