



Refrigeration Equipment Manufacturer

Sandwich Prep Unit

S3BRR-18S

Description: Three solid door sandwich prep unit, 18 cu. ft

Features & Benefits

Stainless steel interior and exterior for greater durability, construction and appearance.

Self-contained **rear-mounted** refrigeration with high humidity coated **fin coil** evaporator.

- Holds 30° F to 42° F for refrigerator

2.5" thick, foamed-in-place polyurethane high density insulation.

Eighteen poly-carbonate, 1/6 size pans. 5" casters standard. **Easy mobility and installation.**

Twelve inch full length removable cutting board.

16 gauge, 300 series stainless steel top.

Heavy-duty overall construction for high-volume, constant duty operation.

Self-closing doors with 90 degree hold open feature and **fully-recessed handles.**

Electric condensate evaporator - **no floor drain required!**

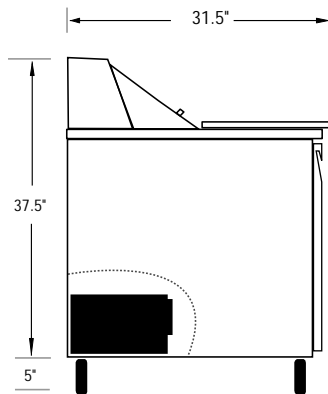

SIDE VIEW

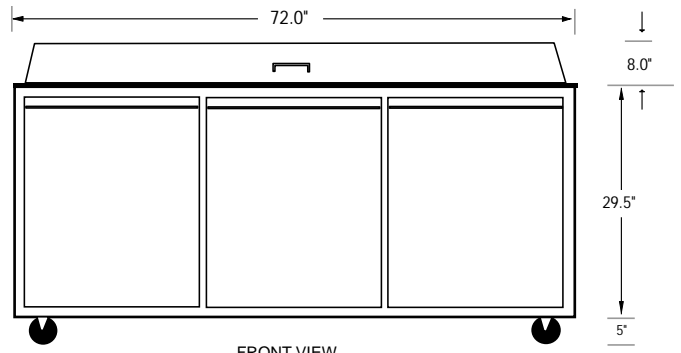

FRONT VIEW

Dimensions	W	D	H
Exterior (inches)	72.0	29.5	37.5
(height with casters)			42.5
Pallet size (inches)	74.0	31.5	4.5

General Information	Cubic Feet Shelves	Pans
Refrigerator	18	18

Shelf size:	22" x 19"
Exterior:	Stainless
Interior:	Stainless
Unit Weight (lbs.)	355
Gross weight (lbs.)	405
Cord length (inches)	79
Nema	5-20p

Volts	115
Amps	7.40 (run)
	11.10 (start)

Compressor Information	# compressors	Refrigerant Capacity
Refrigerant R134A	1	Medium/Low T emp

Use	H.P
Refrigerator	1/2

SPECIFICATIONS SUBJECT TO CHANGE WITHOUT NOTICE

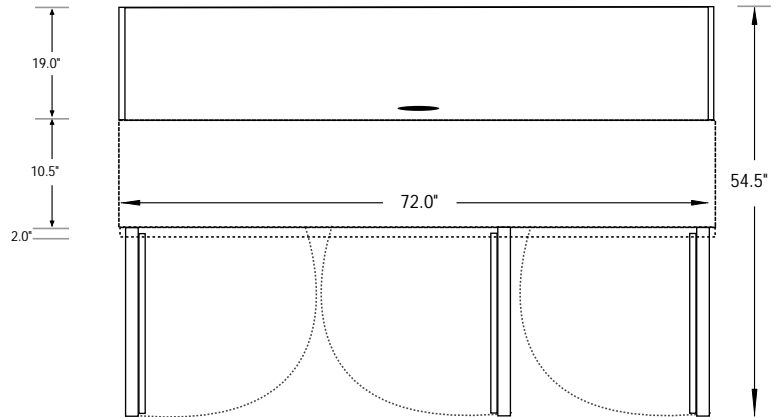

TOP VIEW