

Project: \_\_\_\_\_ Location: \_\_\_\_\_ Item #: \_\_\_\_\_ Quantity: \_\_\_\_\_

**Standard Features**

- Fast cook, low temp, steam and hold modes
- Super Duty heater configuration
- No water or drain line required
- No hood required (in most areas)
- 3 gallon water reservoir
- Heating element not exposed to water
- No deliming, descaling, or blowdowns
- No water quality exclusions to warranty
- Heavy duty door
- Low water protection with light and buzzer
- Heat, cook, and hold indicator lights
- Fast cook and thermostat mode selector switch
- Vacuum and temperature gauges
- NSF certified as a holding cabinet
- 90 minute timer
- Right hand hinged door
- Quick release door—open door while cooking
- Patented vacuum technology for efficiency & faster cooking
- Continuous cook and hold mode settings on timer
- Power on/off switch
- Steamer cavity made of durable reinforced 14 ga. 304 stainless steel
- (2) 5' power cords and plugs included, separate receptacle needed for each unit
- Front mounted drain valve
- Exclusive and patented low temperature steam cooking mode
- Multiple kilowatt outputs available to suit cooking needs
- One year parts and labor warranty
- Lifetime Service and Support Guarantee

**Optional Features**

- Door hinged on left
- 180 minute timer
- Chain package—factory preset hold temperature; controls behind panel
- Military package
- Corrections package—tamper resistant
- Marine package
- Drain kit
- Stainless steel support stand with casters, bullet or flanged feet
- Double stacking stand conversion kit
- Perforated cooking shelf
- Water shield—covers water reservoir
- Steamer door crack open/hold open feature
- 4" full size (12x20x4") drain pan
- One year extended warranty

**Environmental Approvals & Programs**



**Other Approvals**



**Pan Capacities**

Pan Size	Qty.
#200 full size (12x20x2.5")	12
#400 full size (12x20x4")	8



**S6 Double Stacked Steam'N'Hold™**  
Steam Cookers  
shown with double stack stand (with casters) and 4" drain pans

**Short Spec**

Steam'N'Hold™ steamer is AccuTemp Products patented vacuum technology steam cooker with 3 operating modes. Fast cook (212°F), low temperature steam mode (150–200°F) and NSF certified variable temperature hold mode. Steam to be produced inside the cooking cavity with no heating element exposed to water. No water or drain line required. Unit to include heavy duty door which will open at any time during cooking cycle. Steamer to include low water indicator light and buzzer with auto shutdown feature. Unit to be UL, NSF, CE, and Energy Star listed. Built in the USA. Steamers to be mounted on a stainless steel stand.

Steamer Model "D" Specifications PER CAVITY										
Model #	S62081D060 DBL	S62401D060 DBL	S62083D080 DBL	S62083D100 DBL	S62403D110 DBL	S62083D120 DBL	S62403D130 DBL	S62083D150 DBL	S64403D120 DBL	S64803D140 DBL
Volts AC	208	240	208	208	240	208	240	208	440	480
Phase	1	1	3	3	3	3	3	3	3	3
Amps	29	25	22	28	26	33	32	42	16	17
Breaker Size	30 amp	30 amp	30 amp	30 amp	30 amp	50 amp	50 amp	50 amp	20 amp	20 amp
Watts	6kW	6kW	8kW	10kW	11kW	12kW	13kW	15kW	12kW	14kW
NEMA Plug	L6-30P	L6-30P	L15-30P	L15-30P	L15-30P	L15-50P	L15-50P	L15-50P	L16-20P	L16-20P

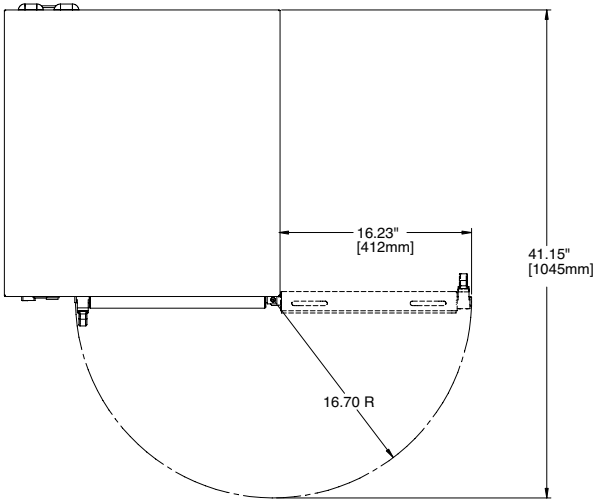

**Notes:**

1. Allow 3" between fryer, ranges, and other hot surfaces.
2. (2) 5' power cords supplied with single or 3 phase, separate receptacle needed for each unit.
3. For use on individual branch circuit only.
4. Do not connect to a circuit operating at more than 150V to ground.
5. Dimensions outside brackets are inches, in brackets are millimeters.

