



ITEM #: \_\_\_\_\_ QTY: \_\_\_\_\_  
 MODEL #: \_\_\_\_\_  
 PROJECT NAME: \_\_\_\_\_

051320

3601 S. Banker St. Effingham, IL 62401 • P.O. BOX 609 • Ph: (888) 431-2667 • Fax: (800) 433-2667

## "SDS" SANITIZER JUG HOLDER

### FEATURES:

- 16-GAUGE CONSTRUCTION
- TYPE 300 STAINLESS STEEL WITH #4 POLISH SATIN FINISH.
- HEIGHT ADJUSTABLE SUPPORT ARM FITS UP TO 16" TALL DISPENSERS WITH LESS THAN 2" DIAMETER COLLAR.
- 8" X 8" BASE FITS DISPENSER BASES UP TO 7" IN DIAMETER.
- BASE PLATE IS SLOTTED FOR THE HEIGHT ADJUSTABLE SUPPORT ARM STABILITY.
- 16" X 16" WEIGHTED SQUARE BASE FOR ADDED STABILITY.
- KNOCKDOWN DESIGN.
- LEVELING FEET.
- NOTE: DISPENSER NOT INCLUDED.



### STAINLESS STEEL SANITIZER JUG HOLDER

MODEL #	QTY
SDS-SB-2	

SOME UNITS SHIP UNASSEMBLED FOR REDUCED SHIPPING COST. ALL DIMENSIONS ARE TYPICAL. TOLERANCE +/- .500"  
 John Boos & Co. is constantly engaged in a program of improving products and therefore reserves the right to change specifications without prior notice.



## DETAILED SPECIFICATIONS

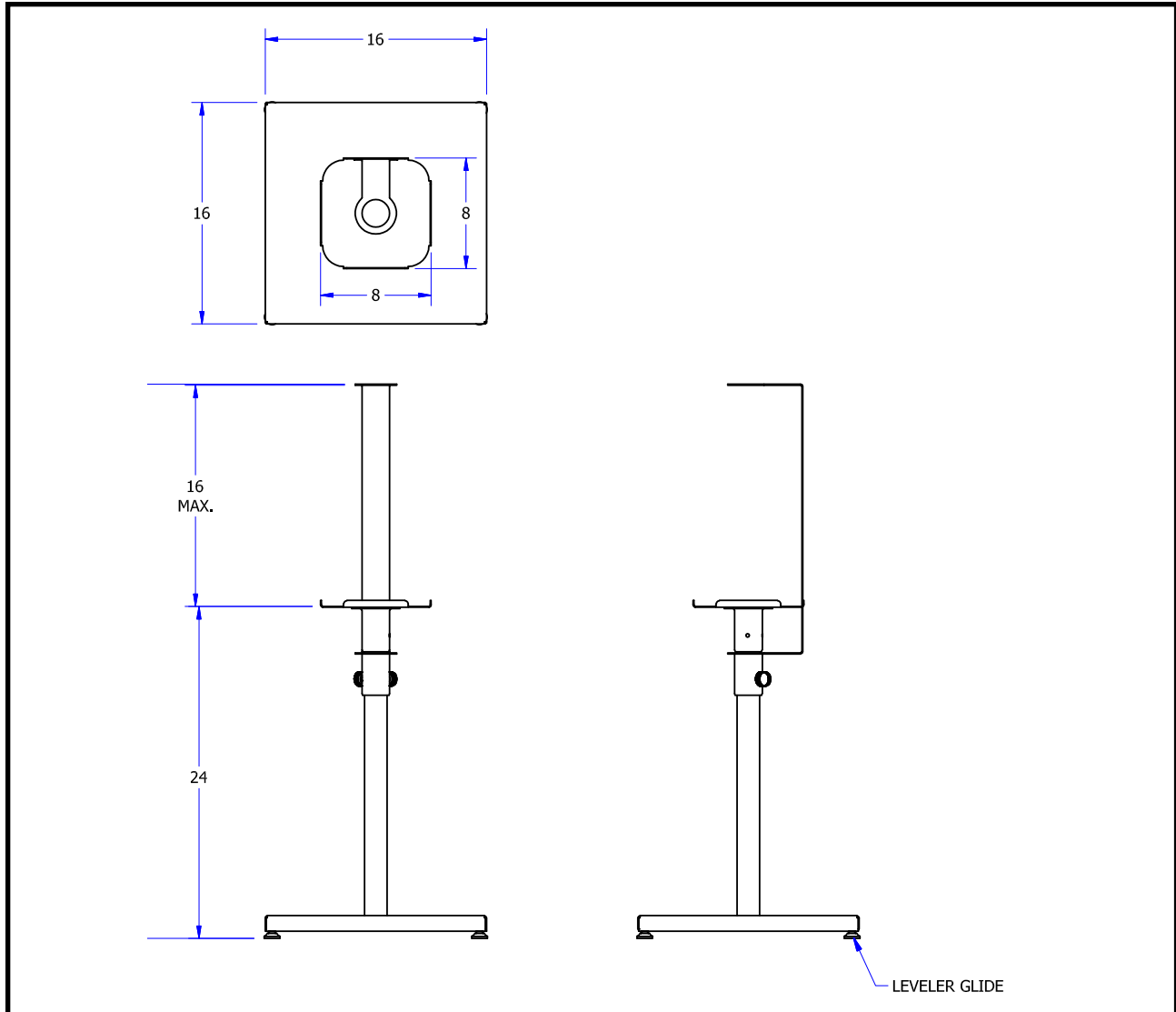

### STAINLESS STEEL SANITIZER JUG HOLDER

MODEL #	SIZE (L X W)	WEIGHT (LBS)
SDS-SB-2	16"X16"	21

SOME UNITS SHIP UNASSEMBLED FOR REDUCED SHIPPING COST. ALL DIMENSIONS ARE TYPICAL. TOLERANCE +/- .500"  
 John Boos & Co. is constantly engaged in a program of improving products and therefore reserves the right to change specifications without prior notice.



3601 S. Banker St. • Effingham, IL 62401 • PO BOX 609 • quotes@johnboos.com

051420

[www.johnboos.com](http://www.johnboos.com)

349