

PLAN VIEW

NOTE:

1. ALL VISIBLE WELDS TO BE GROUND SMOOTH AND POLISHED TO A MATCHING FINISH.
2. ALL NON-VISIBLE WELDS TO BE GROUND SMOOTH AND PAINTED WITH A ELKAY SSP APPROVED PAINT
3. ALL EDGES TO BE SMOOTH AND FREE FROM BURRS

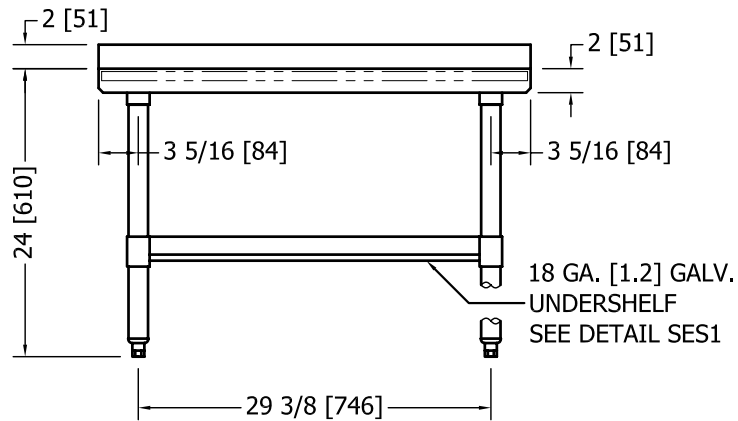

FRONT VIEW

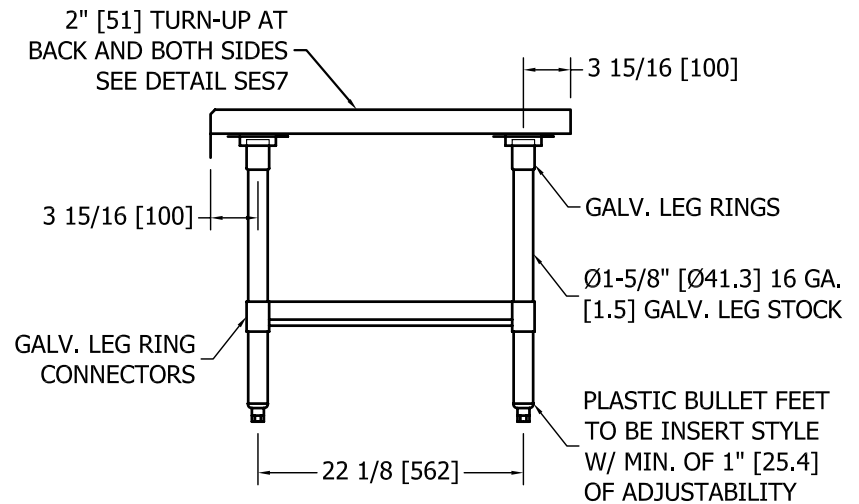

END VIEW

**ELKAY**

Phone: 1-800-726-0553  
Fax: 509-535-1493

**SES30S36-STGX**

DRAWN BY: TCP

DATE: 03/15/12

REVISION: \_\_\_\_\_ DATE - BY: \_\_/\_\_/\_\_

P:\111 CUT SHEETS\EQUIPMENT STANDS\SES-S-STG\SES30S36-STG.DWG

PAGE: 1 OF 1