

PLAN VIEW

NOTE:

1. ALL VISIBLE WELDS TO BE GROUND SMOOTH AND POLISHED TO A MATCHING FINISH.
2. ALL NON-VISIBLE WELDS TO BE GROUND SMOOTH AND PAINTED WITH A ELKAY SSP APPROVED PAINT
3. ALL EDGES TO BE SMOOTH AND FREE FROM BURRS

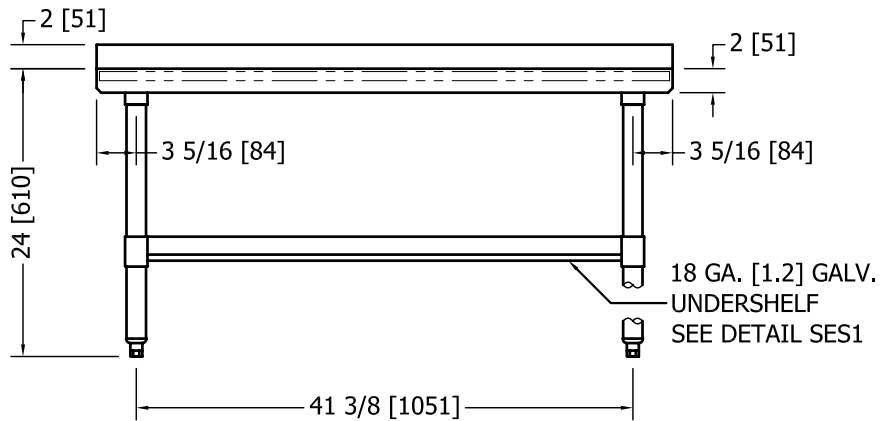

FRONT VIEW

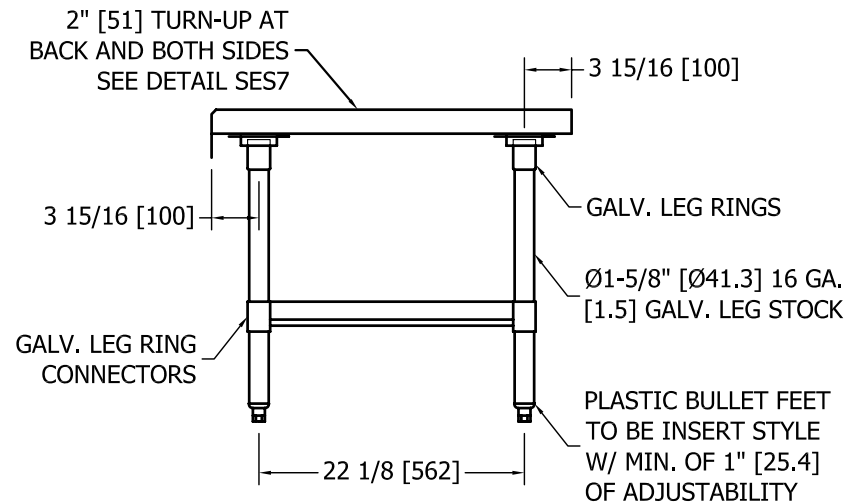

END VIEW



Phone: 1-800-726-0553  
Fax: 509-535-1493

SES30S48-STG

DRAWN BY: TCP

DATE: 11/15/11

REVISED: \_/\_/\_

P:\111 CUT SHEETS\EQUIPMENT STANDS\SES-S-STG\SES30S48STG.DWG

PAGE: 1 OF 1