

APOLLO - MERCURIO

Juicer



Conforms to NSF Std. 08



Easy cleaning



Optional lid for Apollo

APOLLO



APOLLO L



- Commercial, imposing, efficient and easy to use heavy duty citrus juicer range
- Chrome/anodized aluminum body, with no edges or seams for easy cleaning
- removable AISI 304 stainless steel (dishwasher safe) bowl and cover
- Reamer and sieve designed to squeeze with the maximum efficiency
- patented safety interlock on the reamer allows activating the juicer when the product is pushed down
- powerful, ventilated motor with gear drive

Features

Technical:

- The interlock system activates the juicer when the product is pushed down on the reamer. No need to start and stop the machine manually, increases yield.
- The 1/4 Hp motor is fan cooled. Its sealed ball bearing system and the direct gear transmission give a quiet and long lasting operation.
- The tall juice collector reduces splashes to minimum.
- The large spout allows for faster work.
- The internal structure is made from stainless steel for sturdiness and longer life.

Sanitary:

- Only hygienic materials, ABS and stainless steel, enter into contact with the fruit.
- The reamer and the juice collector are easily removable for cleaning.

Specifications

Construction:

The base and reamer are made from sturdy ABS plastic, the juice collector tray is made from stainless steel.

Motor:

1/4 Hp (185W), direct transmission.

Electrical:

120V AC, 60Hz, 1.54 Amp. (220V, 50Hz available on request).

Plug & Cord:

Flexible, 3 wire SJT AWG 18, 6' long.

Controls:

ON / OFF button.



Mercurio



Mercurio L



Reamer small

Reamer big

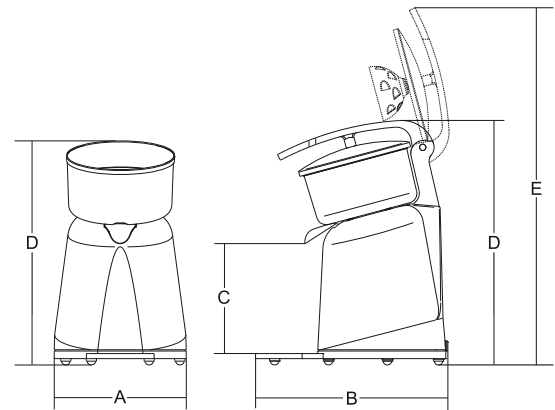
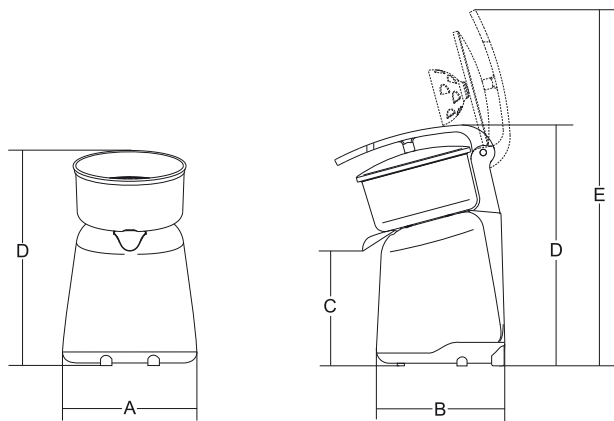

	Power	Power source	Revolutions/min.	A	B	C	D	E	Net weight	Shipping	Gross weight
	watt/Hp		r.p.m.	inch.	inch.	inch.	inch.	inch.	lbs.	inch.	lbs.
Apollo	150/0,20	120V AC, 60Hz, 1.54 Amp.	320	8 ¹ / ₄ "	8 ¹ / ₄ "	6 ¹ / ₈ "	11"	-	7	8 ¹¹ / ₁₆ " x 11" x 14 ⁹ / ₁₆ "	9
Apollo L	150/0,20	120V AC, 60Hz, 1.54 Amp.	320	8 ¹ / ₄ "	10 ⁷ / ₁₆ "	6 ¹ / ₈ "	15 ³ / ₁₆ "	18 ⁷ / ₈ "	8	8 ¹¹ / ₁₆ " x 11" x 14 ⁹ / ₁₆ "	10
Mercurio	150/0,20	120V AC, 60Hz, 1.54 Amp.	320	8 ¹ / ₄ "	11 ¹³ / ₁₆ "	6 ¹³ / ₁₆ "	14"	-	11	15 ³ / ₈ " x 11 ¹³ / ₁₆ " x 17 ⁵ / ₁₆ "	13
Mercurio L	150/0,20	120V AC, 60Hz, 1.54 Amp.	320	8 ¹ / ₄ "	11 ¹³ / ₁₆ "	6 ¹³ / ₁₆ "	15 ³ / ₁₆ "	22 ⁷ / ₁₆ "	13	15 ³ / ₈ " x 11 ¹³ / ₁₆ " x 17 ⁵ / ₁₆ "	15