



Conforms to UL STD. 763 and NSF Std. 08

# MANTEGNA 350 BS TOP - ROSSA

## 14" heavy-duty slicers



Mantegna 350 BS TOP



- 14" high-quality, heavy-duty straight-feed cooked meat slicers
- Designed for precision slicing of all kinds of cooked and cured meats
- Fitted with a double-feed carriage with a double articulating clamping arm holding any product firmly in place
- The TOP version provides even higher durability in terms of reduced maintenance costs with:
  - all knobs, handles, dials and feet in aluminum
  - a fully sealed and waterproof IP 67 switch, with stainless steel on/off buttons
  - no volt release prevents inadvertent reactivation after a power outage
  - complete stainless steel drive shaft assembly

### Features

#### Technical

- The special carriage allows you to slice any kind of cooked meat.
- The sharpener assembly is made entirely from aluminum, no plastic that may break with heavy use.
- The tie rod assembly and all screws are made of stainless steel for longer life.
- The slide shaft is made of ground, chromed steel for a smoother operation.
- The high-quality bushings and ball bearings are self-lubricating.
- The dial thickness control cam system allows for an always precise cut.

#### Safety

- A safety cover is placed under the motor and the electrical components.
- The clamping arm features an exclusive heavy duty plastic protection to keep operator's hand at a safe distance from the blade while operating slicer.

#### Sanitary

- Easy to clean aluminum alloy construction does not crack or stain.
- The screws are stainless steel and resist wear and oxidation.
- The carriage and the center plate are quickly removable without tools.

### Specifications

- Operation:** Vertical feed.
- Construction:** Polished, anodized aluminum alloy.
- Knife 350:** 14" (350 mm), one piece, chromium plated 100Cr6 forged carbon steel blade.
- Sharpener:** Built-in, removable, two stone dual action.
- Slice thickness:** Infinitely variable up to 1<sup>3/16</sup>"
- Motor:** 1/2 Hp (410 W), belt driven, fan cooled.
- Electrical:** 120V AC, 60Hz, 3.10 Amp. (220V, 50Hz available on request).
- Plug and Cord:** Attached, flexible, 3 wire SJT 18 AWG, 6'4" long cord, NEMA 5-15P.
- Switch:** IP 67 controls with stainless steel on/off buttons. No Voltage Release.



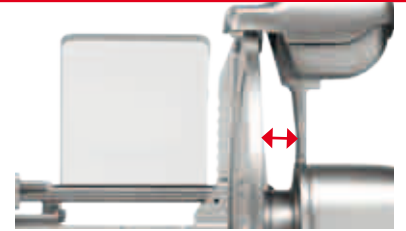
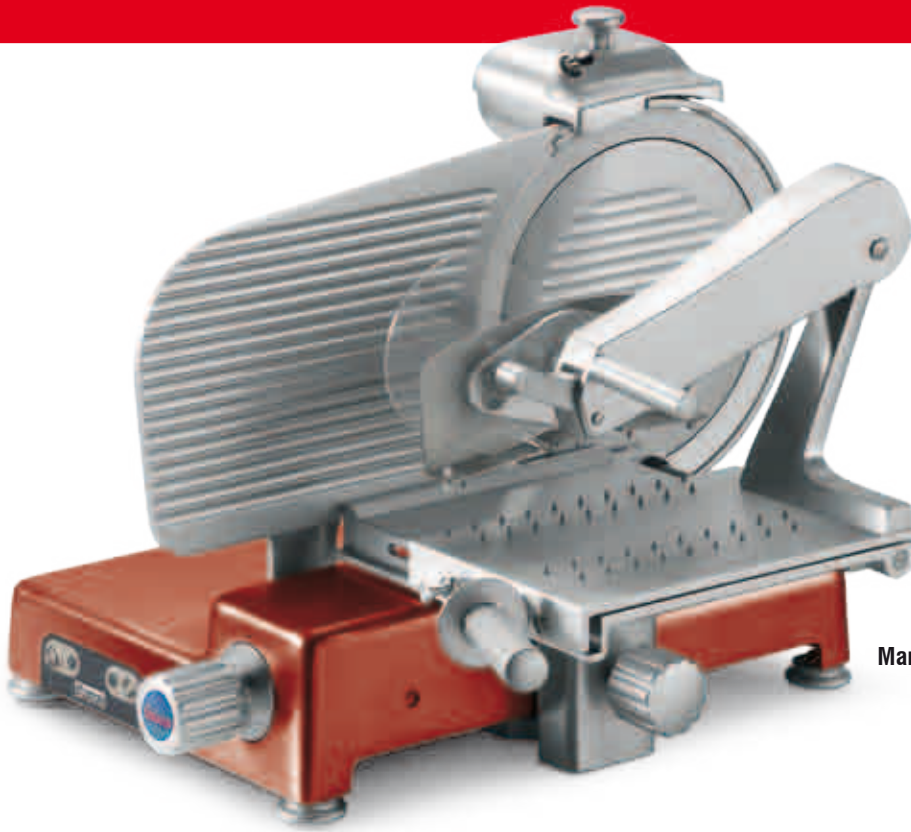

Increased gap between blade and machine body



Removable food pusher

**Mantegna 350 BS TOP ROSSA**

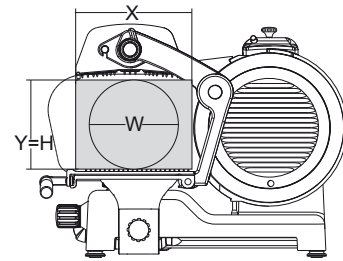
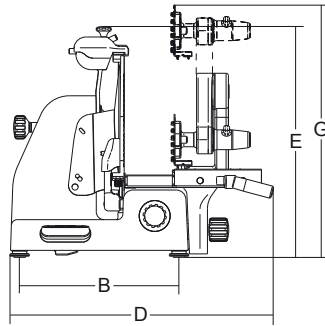
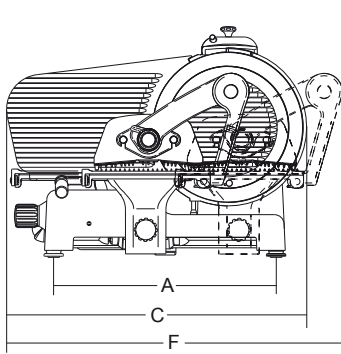

	Ø Blade	Motor	Cut thickness	Blade rpm	Carriage stroke	Hopper	A	B	C	D	E	F	G	X	Y	H	W	Net weight	Shipping	Gross weight
	mm/inch	watt/Hp	inch.	rpm	inch.	inch.	inch.	inch.	inch.	inch.	inch.	inch.	inch.	inch.	inch.	inch.	inch.	lbs.	inch.	lbs.
<b>Mantegna 350 BS TOP</b>	350/14"	410-0,55	13/16"	216	123/16"	1113/16" x 105/8"	187/16"	135/16"	26"	235/8"	207/8"	291/2"	281/8"	105/8"	101/16"	101/16"	101/16"	84	341/4" x 331/16" x 291/2"	117

