

## STANDARD SPECIFICATIONS

### CONSTRUCTION

- Welded stainless steel tank with an extra smooth peened finish ensures easy cleaning.
- Long lasting, high temperature alloy stainless steel baffles are mounted in the heat exchanger elliptical tubes to provide maximum heating and combustion efficiency.
- Elliptical heat tubes have more surface area and will provide greater heat transfer.
- Standing pilot light design provides a ready flame when heat is required.
- Stainless steel front and door, galvanized steel sides and back.
- Fully lined door that will keep outer door at a cooler temperature.

### CONTROLS

- Thermostat maintains selected temperature automatically between 200°F (93°C) and 400°F (204°C).
- Integrated gas control valve acts as a manual valve, and pilot valve, automatic pilot valve, gas filter, pressure regulator, and automatic main valve.
- Gas control valve prevents gas flow to the main burner until pilot is established. Shuts off all gas flow automatically if the pilot flame goes out.
- Temperature limit switch safely shuts off all gas flow if the fryer temperature exceeds the upper limit of 450°F (232°F).

### STANDARD ACCESSORIES

- 2 Twin nickel plated baskets
- Rack type basket support
- 6" (15.2 cm) adjustable legs
- Drain pipe extension
- Flue extension/Diverter
- Battery operated spark ignitor
- 1 year Parts and Labor



### MODELS

- SLG50 Natural 40-50 lbs** 120Kbtu/hr (35 kW) (127 MJ)
- SLG50 Propane 40-50 lbs** 120Kbtu/hr (35 kW) (127 MJ)

### OPERATIONS

- Front 1-1/4" NPT drain valve, for quick draining

### OPTIONS & ACCESSORIES

(AT ADDITIONAL COST)

- Single or triple baskets
- 6" (15.2 cm) adjustable casters
- Fryer cover
- Side splash shield
- Tank channel strip



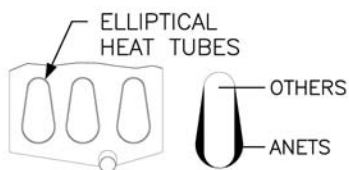

**TAPERED ELLIPTICAL SHAPE**

- 14% MORE SURFACE AREA FOR HEAT TRANSFER
- FOOD PARTICLES CANNOT ACCUMULATE ON TOP OF TUBES

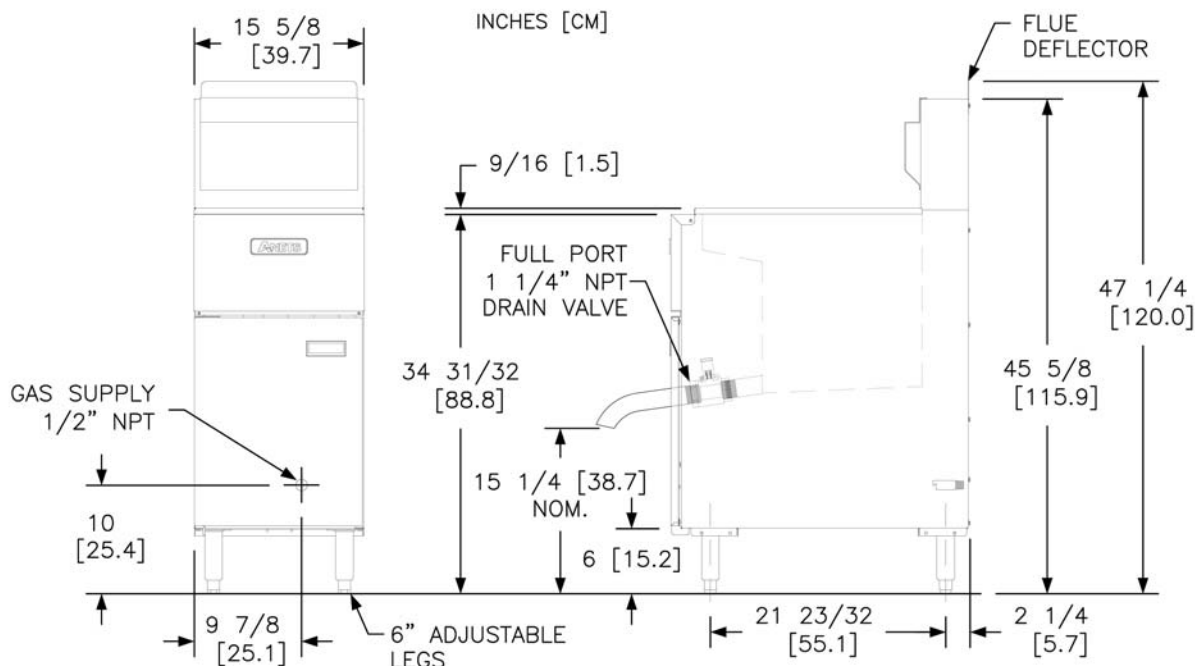
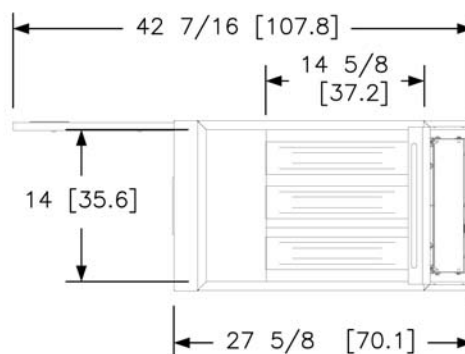

**INDIVIDUAL FRYER SPECIFICATIONS**

Model	Frying Area	Cook Depth	Oil Capacity	Gas Input Rate / Hr	Burner Pressure Nat	Burner Pressure LP
SLG50	14 x 14-5/8 in (35.6 x 37.1 cm)	3-1/2 in (8.9 cm)	40 - 50 Lbs (18 - 23 kg)	120,000 BTUs (35 kW) (127 MJ)	4" W.C. (10 mbars / 1 kPa)	10" W.C. (25 mbars / 2.5 kPa)

**FRYER SHIPPING INFORMATION (Approximate)**

Shipping Weight	Shipping Crate Size H x W x L	Shipping Cube
135 Lbs (61 kg)	46 x 19 x 36 in (116.8 X 48.3 X 91.4 cm)	18.2 ft <sup>3</sup> . (0.5m <sup>3</sup> )

**CLEARANCES**

Front min.	Floor min.	Combustible material		Non-Combustible material		Fryer Flue Area
		Sides min.	Rear min.	Sides min.	Rear min.	
30" (76.2 cm)	6" (15.3 cm)	6" (15.2cm)	6" (15.2cm)	0"	0"	Do not block / restrict flue gases from flowing into hood or install vent hood drains over the flue.

**SHORT FORM SPECIFICATION**

Provide SLG50 tube-fired gas fryers. Fryer shall have an atmospheric burner system combined with stainless steel tubes utilizing high temperature alloy stainless steel baffles. Fryer shall have a deep cool zone; minimum 20% of total oil capacity. Fryer cooking area shall be 14" x 14-5/8" (35.6 x 37.1 cm) with a cooking depth of 3-1/2 (8.9 cm). Heat transfer area shall be a minimum of 863 square inches (5567 sq cm).

**TYPICAL APPLICATION**

Frying a wide variety of foods in a limited amount of space. Frying that requires a medium volume production rate.