

Project

Date

Models

SP 1

SP 2

Item#

Quantity



model SP 2

FEATURES

- Functions with water or milk added to dried base or with ready-to-use mixed product bases to create delicious chilled specialties.
- Creates chilled beverages such as frozen coffee, fruit juices, frozen cocktails, and creamy desserts, like mousses, ice creams, slushes, sherbets, and sorbets.
- One or two, 1.3 gallon (5 L) bowls.
- A compact counter machine with elegant design reliably delivers perfect consistency.
- Easy to clean and user-friendly.
- All the components in contact with product can be removed without tools.
- Transparent bowl encourages impulse purchasing.
- Lockable lid.
- Air cooling.
- Mechanical control board.
- Manual defrost mode.
- Digital display shows the bowls temperature.
- Perfect solution for restaurants, cafeterias, coffee shops, bars, or hotels.
- All models are certified NSF-6 safe for milk.



SP SERIES FROZEN GRANITA AND ICE CREAM DISPENSERS

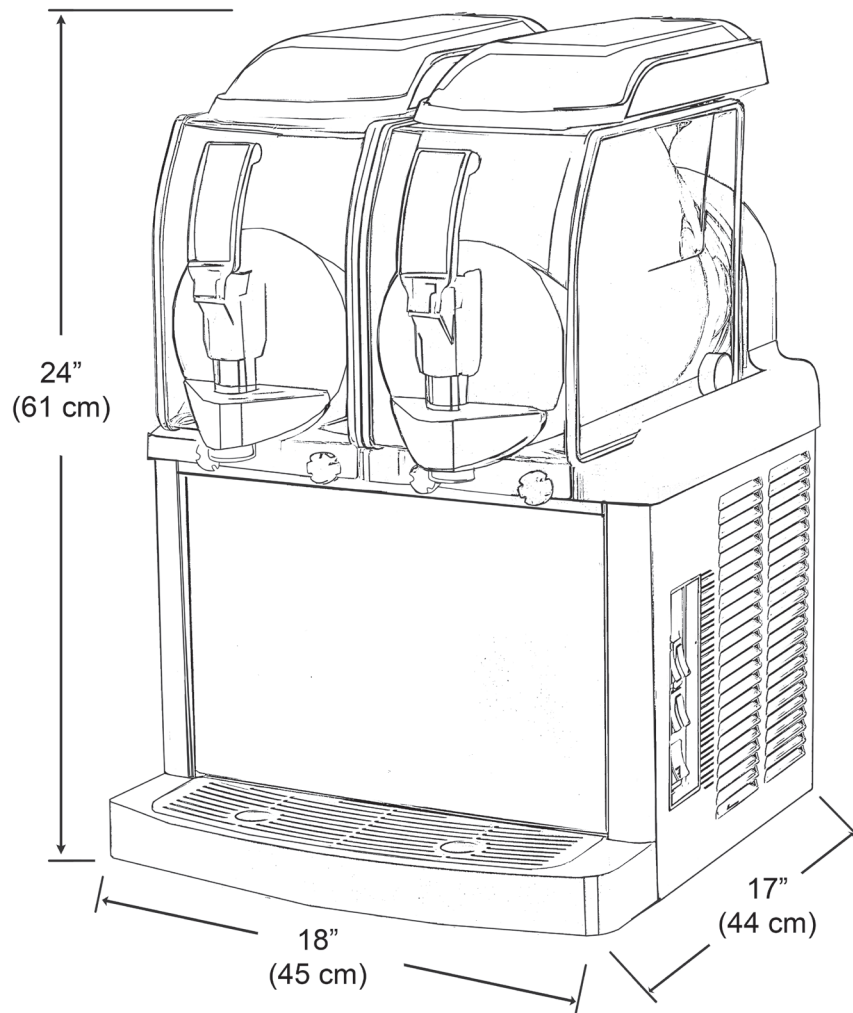

model SP 2

NSF-6



MODELS & SPECIFICATIONS

Model	Description	Electrical	Product Dimensions (H x W x D)	Ship Dimensions (H x W x D)	Product Weight	Ship Weight
SP 1 (1206-008)	(1) 1.3 gallon (5 L) capacity, black finish	115V / 60 Hz 0.44 kW / 5.2 A 1Ph	24" x 10" x 17" (61 cm x 26 cm x 43 cm)	28" x 12" x 19" (71.5 cm x 31.5 cm x 49 cm)	61.7 lbs. (28 kg)	66 lbs. (30 kg)
SP 2 (1206-009)	(2) 1.3 gallon (5 L) capacity, 2.6 gallon (10 L) total capacity, black finish	115V / 60 Hz 0.7 kW / 9.3 A 1Ph	24" x 18" x 17" (61 cm x 45 cm x 44 cm)	25" x 18" x 19" (62.5 cm x 45 cm x 47 cm)	105.8 lbs. (48 kg)	110 lbs. (50 kg)

Refrigeration: R404

Note: Operate at room temperature between 75 - 90° F (24 and 32° C)