



# SRCO-E SRCO-2E

## ELECTRIC CONVECTION OVENS

The SRCO features a modern look and design, form and function for the most demanding kitchens at an affordable price.

The SRCO-E Single Oven comes with the SRCO-LK leg kit, including 4 legs with locking casters

The SRCO-2E Double Stacked Ovens come with the SRCO-SK stacking kit, including heavy duty casters (locking in front), separator tray, exhaust flue extension and mounting hardware.



SRCO-E with 118-SRCOLK



SRCO-2E with 118-SRCOSK

## STANDARD FEATURES

- Power 10kW, 208-240V single phase/three phase-(Please select phase when ordering) (cordset not included, must be hardwired).
- 26" legs on single stack unit for easy access.
- Electronic ignition
- Dial type easy to use thermostat
- Temperature range 150-500°F (65-260°C)
- Electronic one hour timer with alarm buzzer to alert employees and prevent overcooking
- Two Halogen interior lights
- Independent doors with full view windows
- 2-speed, 1/2 hp fan motor (1724, 1140 rpm) for even heat distribution Forced "cool down" fan mode
- Exterior stainless front, top and sides
- Porcelain enamel interior for easy cleaning
- 5 Nickel plated Heavy Duty Racks with eleven position interior rack guide
- Single or three phase connection Insulated
- Cooking chamber reduces heat loss and saves energy
- ETL Safety and Sanitation Certified.



Tel.: 786.600.4687 / Toll Free: 844.218.8477  
Fax: 786.661.4100



Tel.: 514.737.9701 / Toll Free: 888.275.4538  
Fax: 514.342.3854 / Toll Free: 877.453.8832  
sales@mvpgroupcorp.com



www.mvpgroupcorp.com

PROJECT NAME: \_\_\_\_\_

LOCATION: \_\_\_\_\_

ITEM: \_\_\_\_\_ QTY: \_\_\_\_\_

MODEL: \_\_\_\_\_

# TECHNICAL DRAWINGS

## SPECIFICATIONS

| MODEL NUMBER                | SRCO-E                                     | SRCO-2E                  |
|-----------------------------|--|--------------------------|
| EXTERNAL DIMENSIONS (WxDxH) | 38.12" X 44.37" X 60"                      | 38.12" X 44.37" X 65.62" |
| INTERNAL DIMENSIONS (WxDxH) | 29" X 22.5" X 19.75"                       | 29" X 22.5" X 19.75"     |
| RACK CLEARANCE              | 28" WIDTH, 21" DEPTH                       | 28" WIDTH, 21" DEPTH     |
| SHIPPING WEIGHT             | 510 LBS                                    | 1240 LBS                 |
| <u>LEG OR STACKING KITS</u> |  |                          |
| SINGLE OVEN - 118-SRCOLK    | 29.9" X 18.1" X 8.7" H, 2.7 cu ft. 41 lbs. |                          |
| DUAL OVEN - 118-SRCOSK      | 38.2" X 11.8" X 6.7" H, 1.7 cu ft. 35 lbs. |                          |

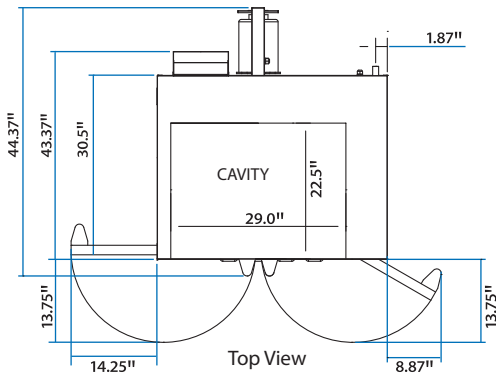

Top View

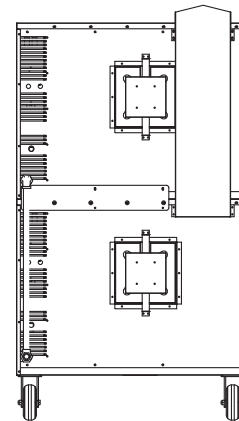
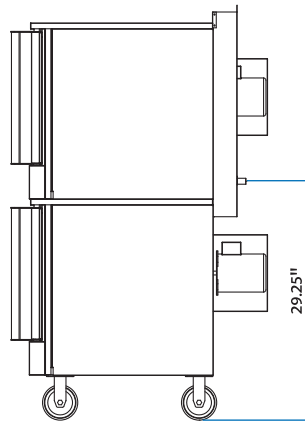
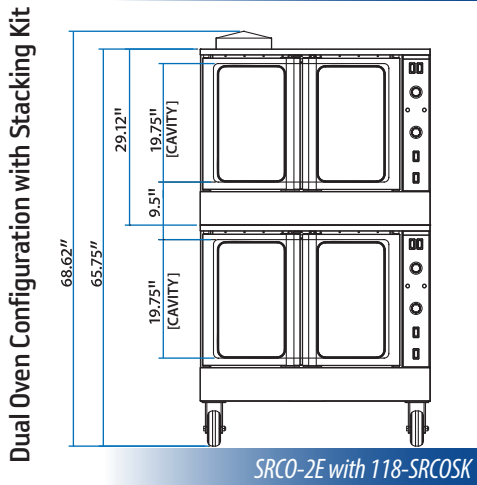
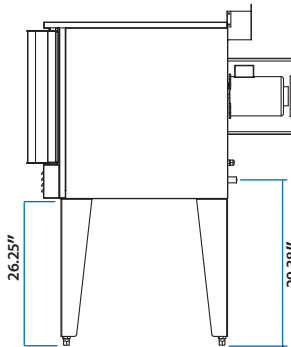
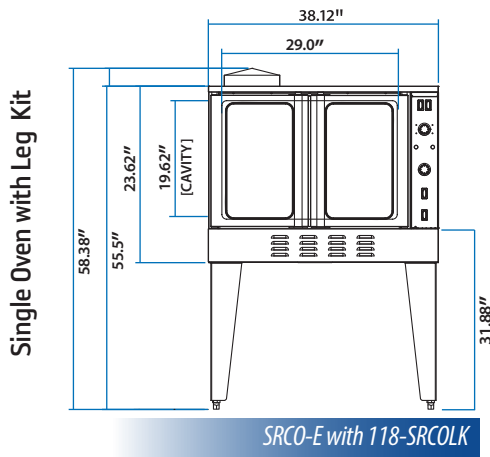

Intertek



Intertek

**Warranty:** 12 months parts & labor.

**Electrical Specifications:**

Voltage: 208-240V, Power: 10KW, Amps Three Phase: 31A

Voltage: 208-240V, Power: 10KW, Amps Single Phase: 46A

**SIERRA RANGE** is a registered trademark of **MVP Group**.

Due to continuing product development, to ensure best possible performance, the specifications are subject to change without prior notice.



Tel.: 786.600.4687 / Toll Free: 844.218.8477  
Fax: 786.661.4100



Tel.: 514.737.9701 / Toll Free: 888.275.4538  
Fax: 514.342.3854 / Toll Free: 877.453.8832

sales@mvpgroupcorp.com