

E**ST-10 ELECTRIC
CONVECTION STEAM COOKER**

JOB NAME: _____

ITEM NO.: _____

NO. REQUIRED: _____

- MODELS:** ST-10M24E24A
 ST-10M24E36A
 ST-10M24E42/48A
 ST-10M36E36A
 ST-10M36E42/48A

SIZE: 24" x Wide x 69.25" High x 33" Front-to-Back
 (610mm Wide x 1759mm High x 838mm Front-to-Back)

36" x Wide x 69.25" High x 33" Front-to-Back
 (914mm Wide x 1759mm High x 838mm Front-to-Back)

DESCRIPTION:

Will be a Market Forge Model _____ electrically powered convection steam cooker. Will be integrally mounted on a cabinet base containing electrically powered steam generator.

The ST-10 will be of double-wall construction with 1" (25mm) thick insulation between cooking compartments and exterior walls, and will have two 18 gauge stainless steel welded cooking compartments with coved internal corners, and a 16 gauge stainless steel front panel.

Each cooking compartment on the ST-10 has a positive slam action, field-reversible door constructed of Type 304 stainless steel. Door latches are spring loaded. The inner door gasket is a one-piece NSF approved silicone rubber gasket. The cooking compartment is equipped with a door interlock (switch) that shuts off steam to the cooking compartment when the door is opened.

Each compartment will be equipped with a perforated steam inlet baffle positioned for precise application of high velocity steam across the surface of food. Controls for each compartment will include a 60-minute load compensating timer with constant steam position, a steamer ready indicator light, steam inlet solenoid valve, pressure relief valve, vacuum breaker, an automatic cold water steam condenser system, and a removable drip trough.

Each compartment will be independently and automatically controlled by setting the cooking time on the 60-minute timer. At the end of cooking time, indicator light will turn off and a continuous signal will sound. Signal is silenced by returning the timer to the OFF position.

Stainless steel cabinet base will match other Market Forge stainless steel equipment and enclose steam generator. Base with stainless steel frame will be equipped with 6" (152mm) stainless steel legs and adjustable bullet feet, reinforced stainless steel counter-top, and stainless steel lift-off front panel.



ST-10M24E36A Shown

Steam generator will be automatically filled with water and brought to pressure when water and heat switches are turned on and automatically drained under pressure when water and heat switches are turned off. A cold water condenser will automatically condense all exhausted steam into water before it is released from the cooker and steam generator drain. Unit also includes safety valves, low water cut-off, water strainer, cathodic protector, and also includes an access for total concept delimer/descaler, and PM Plus (a corrosion inhibitor).

COOKING CAPACITIES:

Each compartment will accommodate the following:

- Eight 12" x 20" x 1" deep pans
- Five 12" x 20" x 2 1/2" deep pans
- Four 12" x 20" x 4" deep pans

OPERATION WILL BE BY:

Electrically powered, A.S.M.E. constructed and National Board Registered, 15 PSI (1kg/cm²) steam generator rated at:

MODEL	CABINET WIDTH	kW
ST-10M24E24A	24" (610mm)	24
ST-10M24E36A	24" (610mm)	36
ST-10M24E42/48A	24" (610mm)	42/48
ST-10M36E36A	36" (914mm)	36
ST-10M36E42/48A	36" (914mm)	42/48

* The manufacturer reserves the right to modify materials and specifications without notice.

SPEC SHEET: S-2476C
04/12FOOD SERVICE EQUIPMENT
10 Pan Electric Convection Steamer**MARKET FORGE**
INDUSTRIES INC.

35 Garvey Street • Everett • MA • 02149
 Tel: (617) 387-4100 • Fax: 1-800-227-2659 (Ex. MA) • (617) 387-4456 (MA and Overseas)
 E-Mail: CUSTSERV@mfi.com • Website: www.mfi.com

A City Discount

E**ST-10 ELECTRIC
CONVECTION STEAM COOKER**

DETAILS & DIMENSIONS

OPTIONAL AT EXTRA COST:

- 12" x 20" x 1 perforated stainless steel pans
- 12" x 20" x 2 1/2" perforated stainless steel pans
- 12" x 20" x 2 1/2" solid stainless steel pans
- 12" x 20" x 4" perforated stainless steel pans
- 12" x 20" x 4" solid stainless steel pans
- Digital countdown timer
- Total concept
- Steam take off kit
- PM Plus

SERVICE CONNECTIONS**Electrically Operated**

EP	Power Supply - Use wire suitable for at least 90°C. Nominal amp per line wire.
Volts	24kW 36kW 42kW 48kW
	3pH 3pH 3pH 3pH
208 (197-219)	67 100 117 ----
240 (220-240)	58 88 ---- 116
480 (460-500)	29 43 ---- 58

Details of other electrical systems available upon request.

CW1 Cold Water - 3/8" (10mm) N.P.T. female for cold water to condenser. Cold water lines will have a maximum of 50 PSI (3.5kg/cm²) and a minimum of 25 PSI (1.8kg/cm²) water pressure. **CAUTION: FILTER SYSTEM INSTALLATION INSTRUCTIONS MUST BE ADHERED TO WHEN CONNECTING A FILTER TO THIS LINE.**

CW2 Cold Water - 3/8" (10mm) N.P.T. female for cold water to condenser. Cold water lines will have a maximum of 50 PSI (3.5kg/cm²) and a minimum of 25 PSI (1.8kg/cm²) water pressure.

EC Electrical Connection - 120 VAC, 60 Hz, 1/2" (13mm) conduit connection or equivalent. Use wire suitable for at least 90°C. Amp draw for cooker and boiler controls: 6 amps.

ST Steam Take-off - Connection for operations of adjacent steam powered equipment. Requires steam take-off kit (*optional at extra cost*).

D Drain - Pipe full 2" (50mm) N.P.T. female to flush floor drain capable of receiving water flowing at a maximum rate of 5 gallons (19 liters) per minute. **DO NOT MAKE SOLID CONNECTION TO FLOOR DRAIN. INSTALL NO ELBOWS IN DRAIN LINE.**

NOTE: The only available space to supply utilities to the generator is the 6" (152mm) space between the floor and the cabinet base. PVC & CPVC Pipe are not acceptable materials for drains.

CAUTION: Before connecting water to this unit, have water supply analyzed to make sure hardness is no greater than 2.0 grains and pH level is within the range of 7.0-8.5. Water which fails to meet these standards should be treated by installation of a water conditioner. **EQUIPMENT FAILURE CAUSED BY INADEQUATE WATER QUALITY IS NOT COVERED UNDER WARRANTY.**

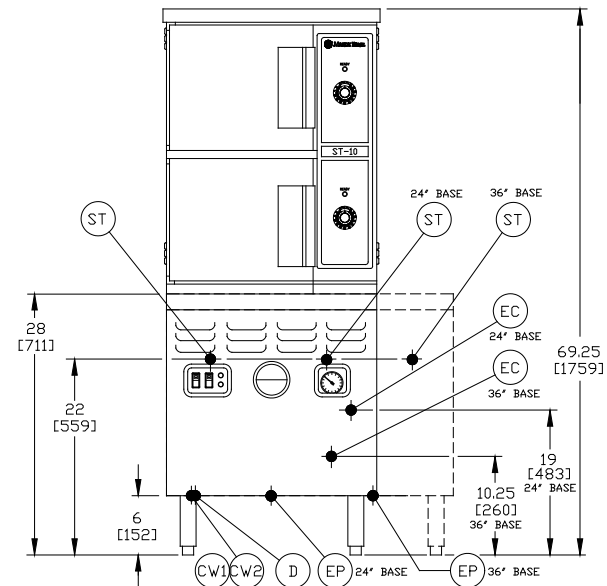
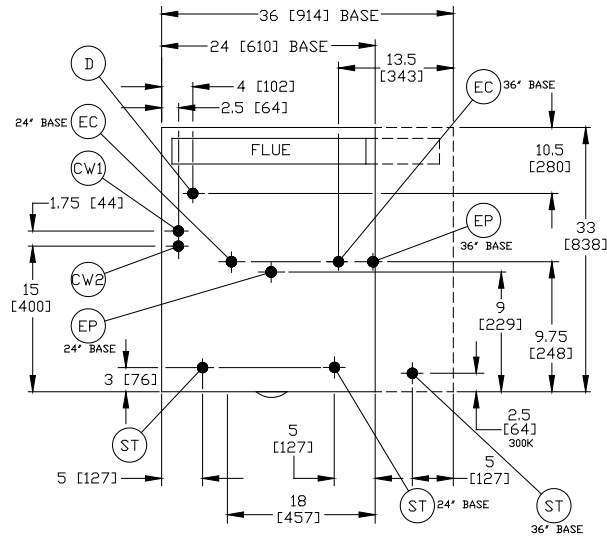

It is our policy to build equipment which is design certified by U.L., A.S.M.E., N.S.F., and C.S.A. However, a continuing program of product improvement makes it necessary to submit new models to the agencies as they are developed and consequently not all models bear the appropriate agency labels at all times.

SPEC SHEET: S-2476C
04/12FOOD SERVICE EQUIPMENT
10 Pan Electric Convection Steamer**MARKET FORGE**
INDUSTRIES INC.

PRINTED IN U.S.A.

35 Garvey Street • Everett • MA • 02149
Tel: (617) 387-4100 • Fax: 1-800-227-2659 (Ex. MA) • (617) 387-4456 (MA and Overseas)
E-Mail: CUSTSERV@mfi.com • Website: www.mfii.com

A City Discount