

Project: _____	AIA# _____
Item #: _____ Qty: _____	SIS# _____
Model #: _____	

## Wet Waste Sink Cabinets

SWB-12-C, SWB-18-DW, SWB-18-DB,  
 SWB-24L-C, SWB-24R-C



**Intertek**  
 4004503  
 Conforms to ANSI/NSF STD 2  
 Certified to CSA/CAN STD B45.4

### Standard Features

- Manufactured with total welded construction to meet NSF® standards
- All stainless steel construction
- Adjustable stainless steel bullet feet
- 9-1/4" by 11-1/2" by 6" deep sink bowl with hot and cold water gooseneck faucet
- Faucets are standard and ship mounted
- Lift-out perforated plastic wet waste strainer
- Model SWB-12-C has a cabinet base with front hinged access door with lock and storage space for three 1-gallon chemical containers
- Model SWB-18-DW has a cabinet base with work surface trash chute hole and front hinged access door with lock (stainless steel trash container, model DWC, is available as an accessory)
- Model SWB-18-DB has a drainboard work surface with recessed wet waste sink below
- Models SWB-24L-C and SWB-24R-C include a 12" drain board section in the work surface and an open front cabinet base with center vertical divider. The L or R in the model number designates the sink location as left or right.

★ **All faucets are NSF/ANSI 61, Annex G low lead compliant**

<b>Specifications</b>	<b>Product Information</b>
-----------------------	----------------------------

- Drain**
- 1-1/2" I.P.S. Threaded drain will fit Dearborn part #8033 slipnut and part #W-573P washer.
- Faucet**
- Deck mount on 4" centers, accepts 3/8" sink leads, hot and cold water connections required
- Sink Bowl Dimensions**
- 9-1/4" by 11-1/2" by 6" deep
- Sink Strainer**
- Perforated plastic
- Legs**
- 1-5/8" diameter, 16 gauge stainless steel
  - Stainless steel bullet feet
- Materials**
- 20 gauge stainless steel parts include: all components unless otherwise noted
  - 18 gauge stainless steel parts include: leg pads

Wet waste sink cabinets are offered in five different 24" deep models. The 12" wide chemical storage cabinet holds three 1-gallon chemical containers. The 18" wide dry waste cabinet holds a trash receptacle and has a 6" round trash chute in the work surface. The trash receptacle is not included, but a stainless steel dry waste container is available as an accessory, specify model number DWC. The 18" wide drainboard model includes a drainboard work surface with recessed wet waste sink below.

The two 24" wide models include a 12" drainboard section with lift-out perforated insert and open front cabinet base. A vertical center divider allows three 1-gallon chemical containers to be stored below the sink with the other side of the cabinet available for additional storage. The wet waste sink may be located to the left or right.

To view underbar installation instructions, please visit: [http://www.glastender.com/PDF/F-750-165\\_Underbar\\_Installation\\_Instructions.pdf](http://www.glastender.com/PDF/F-750-165_Underbar_Installation_Instructions.pdf)  
 To view cleaning and care instructions, please visit: [http://www.glastender.com/PDF/F-423-011\\_ss\\_clean\\_care.pdf](http://www.glastender.com/PDF/F-423-011_ss_clean_care.pdf)

<b>Glastender, Inc.</b> • 5400 N Michigan Rd • Saginaw, MI • 48604-9780 989.752.4275 • 800.748.0423 • Fax 989.752.4444 <a href="http://www.glastender.com">www.glastender.com</a>	Approval/Notes:
Specifications subject to change without notice. For current specifications please visit our website.	

# Wet Waste Sink Cabinets

## Dimensional Information

SWB-12-C

SWB-18-DW

SWB-18-DB

SWB-24L-C

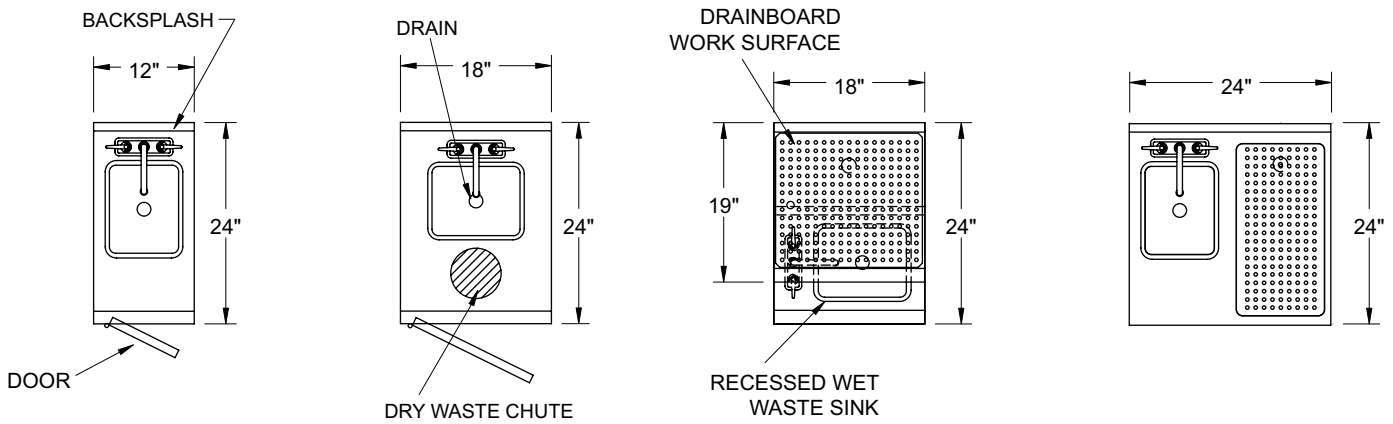

## PLAN VIEWS

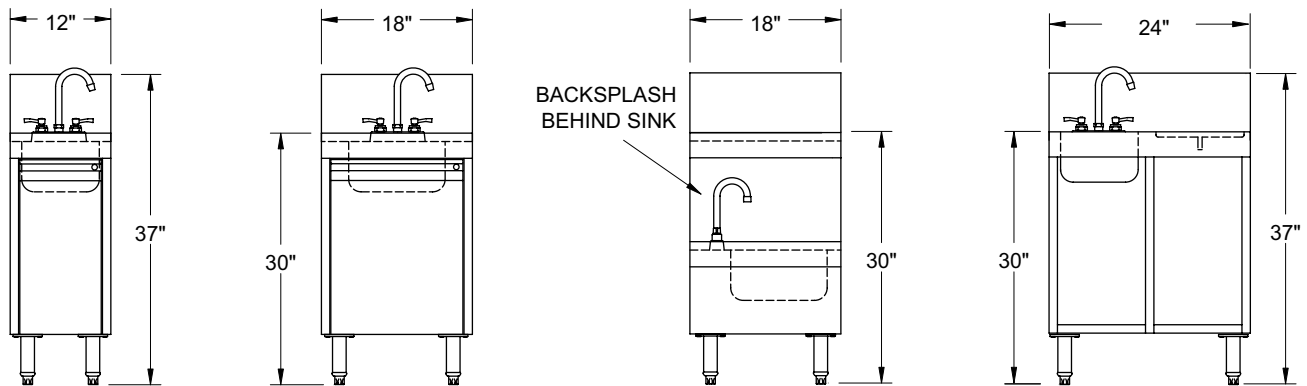

## FRONT ELEVATIONS

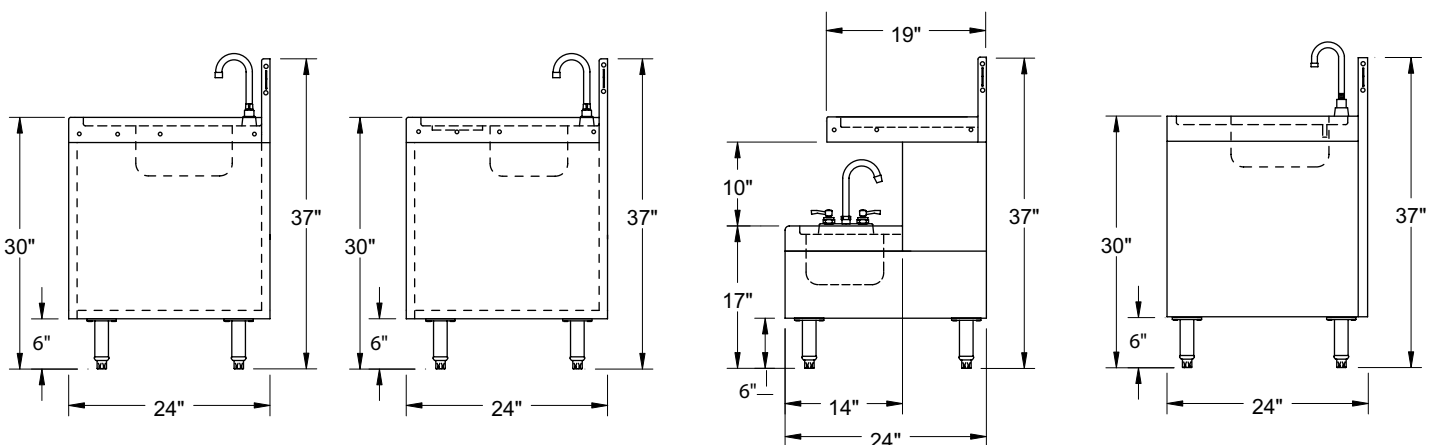

## SIDE ELEVATIONS



5400 N Michigan Rd • Saginaw, MI • 48604-9780  
 989.752.4275 • 800.748.0423 • Fax 989.752.4444  
[www.glastender.com](http://www.glastender.com)

Printed in USA