



VEGETABLE PREPARATION MACHINE CA-21 2D 120/60/1 · 2 DISCS INCLUDED

Compact, 1-speed vegetable slicer.

P/N. 1050954



- ✓ Lever and lid easily removable for cleaning purposes.
- ✓ Stainless steel, dishwasher-safe discs. The removable blades allow for an even more thorough and efficient cleaning.
- ✓ Combination of safety systems: head, cover, power switch.
- ✓ Complete error warning system.
- ✓ Appliance certified by NSF International (regulations on hygiene, cleaning and materials suitable for contact with foods).
- ✓ 100% tested.

INCLUDES

- ✓ 1-speed motor block.
- ✓ Vegetable slicer attachment.
- ✓ Gravity product expulsion ramp.
- ✓ Ejection disc.
- ✓ CA-21 2D includes 2 discs: FCS-4 (4 mm. slicing disc) and SHS-2 (2 mm. shredding disc).

OPTIONS

- Cutter bowl.
- Hub with smooth blades.
- Hub with toothed blades.
- Hub with perforated blades.

ACCESSORIES

- Cutter bowl (Compact line)
- FCS Slicing Discs (Compact line)
- SHS Shredding & Grating Discs (Compact line)
- Hubs with blades (Compact)

SPECIFICATIONS

Hourly production (pieces): 110 lbs - 770 lbs

Inlet opening: 13.8 in²

Disc diameter: 7.1 "

Motor speed: 1800 rpm

Total loading: 1.5 Hp (12 A)

Electrical supply: 120 V / 60 Hz / 1 ~ (4 A)

Plug: --

Electrical connection: --

Noise level (1m.): <70 dB(A)

Background noise: 32 dB(A)

External dimensions (WxDxH)

Width: 14.9 "

Depth: 12.2 "

Height: 21 "

Net weight: 33.5 lbs

Crated dimensions

11.2 x 15.2 x 28.1 "

Volume Packed: 0.8 m³

Gross weight: 43.0 lbs.

SALES DESCRIPTION

Compact ACTIVE line. 1-speed motor block + vegetable slicer attachment.

A perfect cut

- ✓ High precision settings and comprehensive cutter and disc design aimed at obtaining a perfect cut.
- ✓ Gravity product expulsion ramp allow to reconstruct the sliced product for storing or presentation purpose.
- ✓ Ejection disc included for the products that require its use.
- ✓ Can be fitted with a wide range of discs and grids of the highest cutting quality.
- ✓ Combining these accessories together to obtain more than 35 different types of cuts and grating grades.
Possibility of extending its functionality by adding the cutter bowl with blades.

Built to last

- ✓ Sturdy construction in food-grade best quality materials.
- ✓ High power asynchronous motor.

Maximum comfort for the user

- ✓ Ergonomic design: product sliced in one single movement.
- ✓ Lateral product output: requires less space on the worktop and guides the product, avoiding splashes.
- ✓ Adjustable product ejection direction to adapt to the workflow in the preparation area.
- ✓ Recessed cored relief allows for any position in the kitchen, side walls, back wall, light and compact, this machine can fit.
- ✓ The electronic command panel is very intuitive.

Maintenance, safety, hygiene



DYNAMIC PREPARATION
COMMERCIAL VEGETABLE PREPARATION MACHINES

product sheet
updated 03/21/22



VEGETABLE PREPARATION MACHINE CA-21 2D 120/60/1 · 2 DISCS INCLUDED

Compact, 1-speed vegetable slicer.



P/N. 1050954

DYNAMIC PREPARATION
COMMERCIAL VEGETABLE PREPARATION MACHINES

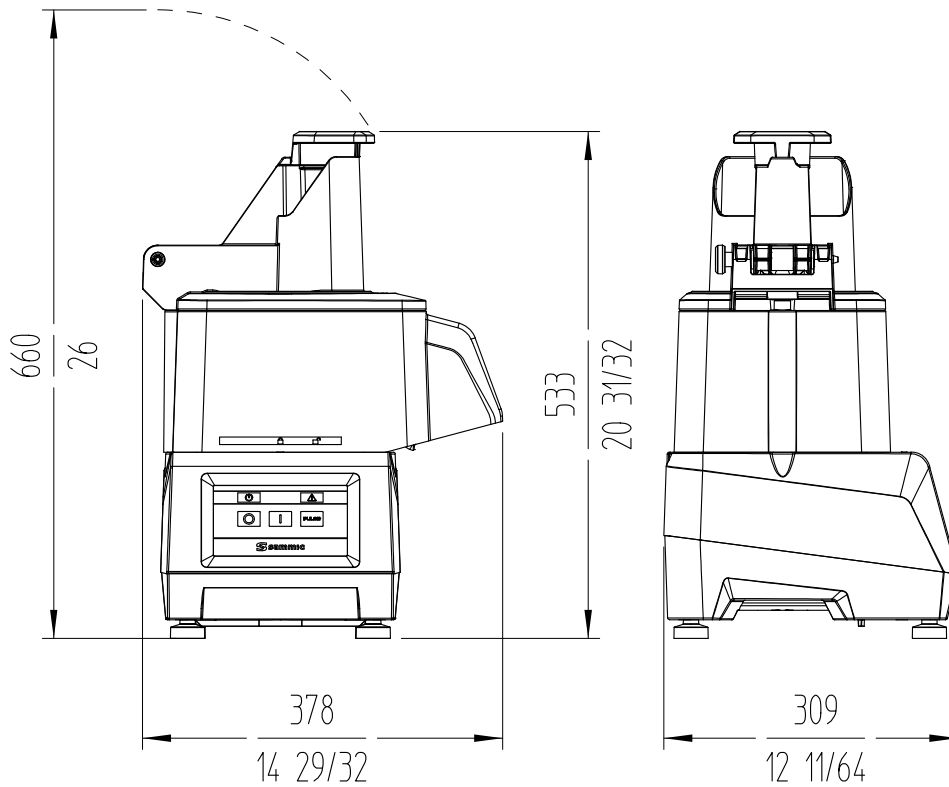

sammic | www.sammic.us
Food Service Equipment Manufacturer

usa@sammic.com
1225 Hartrey Avenue
60202-1056 Evanston, IL

phone +1 (224) 307-2232
toll free +1 844 275 3848



Project	Date
Item	Qty
Approved	

product sheet
updated 03/21/22