



[COMING SOON] CUTTER-EMULSIFIER KE-4V 120/50-60/1

Compact bowl cutter & emulsifier. Adjustable speed with brushless technology.



P/N. 1051008

- ✓ Very uniform finish due to the movement generated by the special position of the cutting edges.
- ✓ Depending on usage, optional smooth or perforated blades available.
- ✓ Special programmes: thick and fine grinding.
- ✓ Optional vegetable slicer attachment available.

Built to last

- ✓ Sturdy construction in food-grade best quality materials.

Maximum comfort for the user

- ✓ Cutter bowl equipped with ergonomic handle.
- ✓ Advanced control panel that is very intuitive to use and offers all the information at a glance.
- ✓ Control panel equipped with timer to standardise processes.
- ✓ Recessed cord relief allowing flush against wall operation

Maintenance, safety, hygiene

- ✓ Safety microswitches in the position of the bowl and the lid.
- ✓ Complete error warning system.
- ✓ Appliance certified by NSF International (regulations on hygiene, cleaning and materials suitable for contact with foods).
- ✓ 100% tested.

SALES DESCRIPTION

Compact ULTRA line. Variable speed motor block + 4,4 l cutter bowl.

Equipped with “brushless” technology: powerful and efficient motors.

- ✓ Maximum efficiency: maintain the torque throughout the speed range.
- ✓ Lightweight and compact design: they weigh less, they occupy less space.
- ✓ Improved air/water-tightness since no ventilation is required.
- ✓ They generate less noise: improved workplace environment.

Efficiency and performance.

- ✓ Possibility of programming by time and pulse button.
- ✓ 4.4 lt-bowl equipped with lateral stirrer and high shaft for larger production capacity.
- ✓ Transparent polycarbonate lid equipped with hole to add ingredients in use.
- ✓ Lid complete with gasket to avoid product overflowing.
- ✓ Homogeneous and fine mixing result thanks to the lateral stirrers and inverted blade.
- ✓ The lateral stirrers avoid product overheating.

INCLUDES

- ✓ Variable speed motor block.
- ✓ Cutter bowl with toothed blades.

ACCESSORIES

- Hub with smooth blades.
- Vegetable slicer attachment.
- Hub with perforated blades.



sammic | www.sammic.us
Food Service Equipment Manufacturer

usa@sammic.com phone +1 (224) 307-2232
1225 Hartrey Avenue toll free +1 844 275 3848
60202-1056 Evanston, IL



Project	Date
Item	Qty
Approved	

product sheet
updated 11/08/21

DYNAMIC PREPARATION
CUTTER-MIXERS & EMULSIFIERS



[COMING SOON] CUTTER-EMULSIFIER KE-4V 120/50-60/1

Compact bowl cutter & emulsifier. Adjustable speed with brushless technology.



SPECIFICATIONS

Electrical supply: 120 V / 50-60 Hz / 1 ~
 (5.3 A)
 Plug: USA (NEMA 5-15P / 2P+G)
 Bowl capacity: 4.65 qt.
 Max. product capacity: 5.5 lbs.
 Maximum capacity (liquid): 2.5 qt.
 Bowl dimensions: Ø7.6 " x 6.34 "
 Total loading: 2 Hp (14 A)
 Speed, min-max: 300 rpm - 3000 rpm

External dimensions (WxDxH)

- ✓ Width: 9.9 "
 - ✓ Depth: 12.2 "
 - ✓ Height: 17.1 "
- Net weight: 26.2 lbs.

Crated dimensions

11.2 x 15.2 x 27.4 "
 Volume Packed: 0.08 m³
 Gross weight: 34.2 lbs.

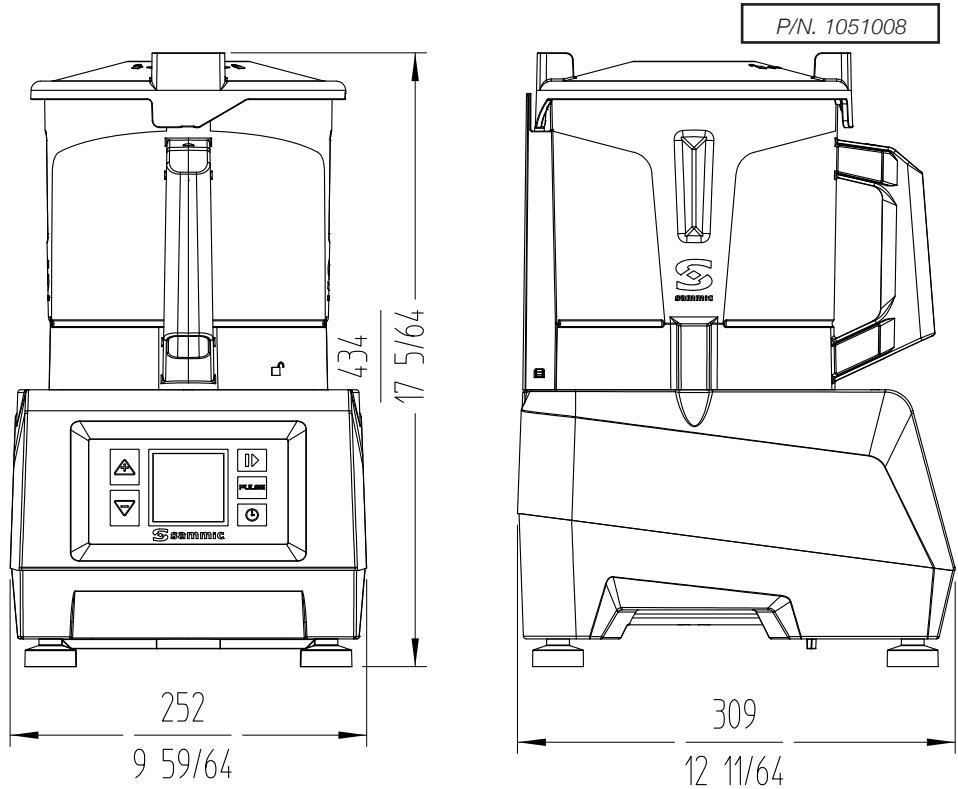

DYNAMIC PREPARATION
CUTTER-MIXERS & EMULSIFIERS

sammic | www.sammic.us
Food Service Equipment Manufacturer

usa@sammic.com phone +1 (224) 307-2232
 1225 Hartrey Avenue toll free +1 844 275 3848
 60202-1056 Evanston, IL



Project	Date
Item	Qty
Approved	

product sheet
updated 11/08/21