



IMMERSION BLENDER & WHISK COMBO MB-31 120/50-60/1 USA

Professional hand blender and beater. 0.54 Hp.



P/N. 3030801

- ✓ Intuitive use: very simple operation. LED warning light in two colours to indicate the status of the machine.

Built to last

- ✓ Professional performance: capable of carrying out prolonged work without the casing overheating.
- ✓ Life-plus: equipped with a motor which has passed all of the most demanding usage tests.
- ✓ Studied geometry: casing designed to avoid rolling and falling.
- ✓ Easy to clean: detachable arms, can be cleaned under the tap.
- ✓ Approved by NSF: guaranteed safety and hygiene.

INCLUDES

- ✓ Variable speed motor block.
- ✓ Whisk BA-30.
- ✓ MA-31 mixer arm.
- ✓ Wall mount.

ACCESSORIES

- Mixer arms MA-30
- Whisk BA-30



SALES DESCRIPTION

Variable speed motor block.
12.05" detachable mixer arm designed for continuous use in recipients of up to 32qt.
Whisk with capacity for 2 to 50 egg whites.

All-in-one

- ✓ Professional hand blender and beater.
- ✓ Professional hand blender designed for carrying out different preparations without the need for add-on tools.
- ✓ Professional Y-blade, made from tempered steel and with a long-duration cutting edge.
- ✓ Vario-speed: variable speed.
- ✓ Mixer arm designed to work in recipients of up to 30 litres.
- ✓ Beater with capacity for 2 to 50 egg whites.

Maximum comfort for the user

- ✓ Compact design: logical and manageable size.
- ✓ Ergo-design & bi-mat-grip: external casing made in two materials for an ergonomic hold. Anti-slip grip. Optimum inclination of handle, minimising fatigue.
- ✓ Click-on-arm: detachable arm with fast and secure closure.
- ✓ Mixer arm hood designed to avoid splashes.



sammic | www.sammic.us
Food Service Equipment Manufacturer

usa@sammic.com
1225 Hartrey Avenue
60202-1056 Evanston, IL

phone +1 (224) 307-2232
toll free +1 844 275 3848



Project	Date
Item	Qty
Approved	

product sheet
updated 09/25/20

DYNAMIC PREPARATION
COMMERCIAL HAND BLENDERS - XM RANGE



IMMERSION BLENDER & WHISK COMBO MB-31 120/50-60/1 USA

Professional hand blender and beater. 0.54 Hp.



P/N. 3030801

SPECIFICATIONS

Total loading: 0.54 Hp
Electrical supply: 120 V / 50-60 Hz / 1 ~
(3.5 A)
Plug: --

Liquidiser function

Maximum recipient capacity: 32 qt.
Motor speed: 1500 - 12000 rpm
Blade diameter: 2.17 "
Blade guard diameter: 3.6 "
Liquidising arm length: 12.05 "
Total length: 24.21 "

Whisk function

Motor speed: 200 - 1500 rpm
Capacity (egg whites): 2 - 50
Revolving arm length: 15.6 "
Total length (with revolving arm): 27.7 "

Net weight: 10.16 lbs.

Noise level (1m.): <80 dB(A)

Crated dimensions

17.9 x 18.7 x 4.6 "
Gross weight: 12.3 lbs.

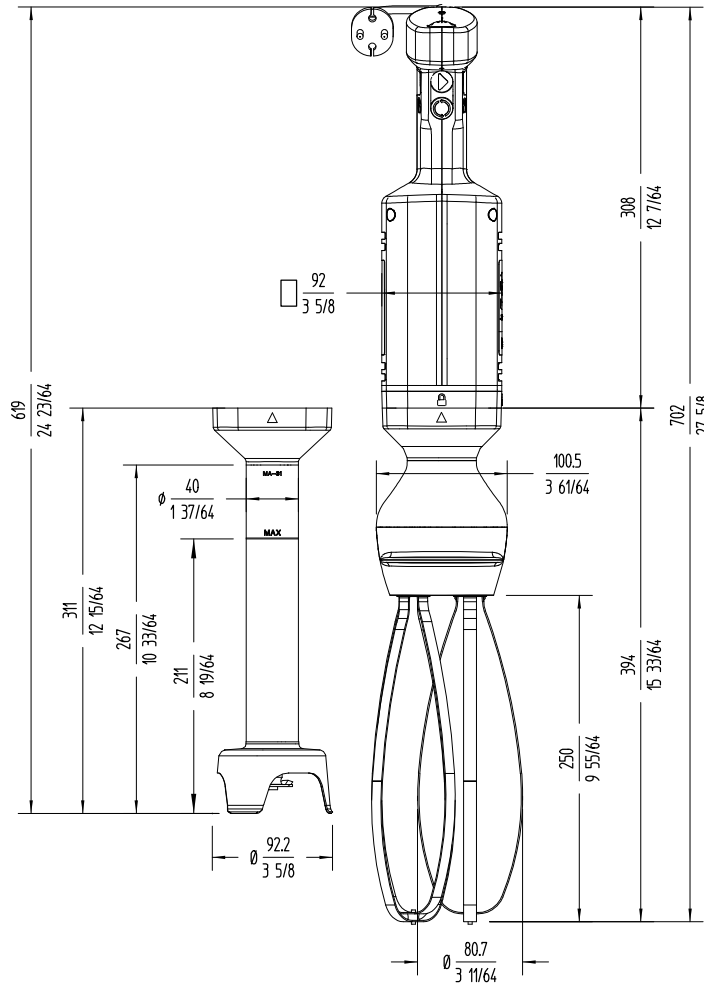

DYNAMIC PREPARATION
COMMERCIAL HAND BLENDERS - XM RANGE

sammic | www.sammic.us
Food Service Equipment Manufacturer

usa@sammic.com phone +1 (224) 307-2232
1225 Hartrey Avenue toll free +1 844 275 3848
60202-1056 Evanston, IL



Project	Date
Item	Qty
Approved	

product sheet
updated 09/25/20