



# IMMERSION BLENDER & WHISK COMBO MB-51 120/50-60/1 USA

Professional hand blender and beater. 1.1 Hp.



P/N. 3030831



- ✓ Intuitive use: very simple operation. LED warning light in two colours to indicate the status of the machine.
- ✓ Possibility of continuous operation.

### Built to last

- ✓ Professional performance: capable of carrying out prolonged work without the casing overheating.
- ✓ Life-plus: equipped with a motor which has passed all of the most demanding usage tests.
- ✓ Studied geometry: casing designed to avoid rolling and falling.
- ✓ Easy to clean: detachable arms, can be cleaned under the tap.
- ✓ Approved by NSF: guaranteed safety and hygiene.

### INCLUDES

- ✓ Variable speed motor block.
- ✓ Whisk BA-50.
- ✓ MA-51 mixer arm.
- ✓ Wall mount.

### ACCESSORIES

- Mixer arms MA-50
- Whisk BA-50

## SALES DESCRIPTION

Variable speed motor block.  
16.70" detachable mixer arm designed for continuous use in recipients of up to 85qt.  
Whisk with capacity for 2 to 80 egg whites.

### All-in-one

- ✓ Professional hand blender and beater.
- ✓ Professional hand blender designed for carrying out different preparations without the need for add-on tools.
- ✓ Professional Y-blade, made from tempered steel and with a long-duration cutting edge.
- ✓ Vario-speed: variable speed.
- ✓ Mixer arm designed to work in recipients of up to 80 litres.
- ✓ Beater with capacity for 2 to 100 egg whites.

### Maximum comfort for the user

- ✓ Logical and manageable size.
- ✓ Ergo-design & bi-mat-grip: external casing made in two materials for an ergonomic hold. Anti-slip grip. Optimum inclination of handle, minimising fatigue.
- ✓ Click-on-arm: detachable arm with fast and secure closure.
- ✓ Mixer arm hood designed to avoid splashes.



**sammic** | www.sammic.us  
Food Service Equipment Manufacturer

usa@sammic.com  
1225 Hartrey Avenue  
60202-1056 Evanston, IL

phone +1 (224) 307-2232  
toll free +1 844 275 3848



Project	Date
Item	Qty
Approved	

product sheet  
updated 09/24/20

DYNAMIC PREPARATION  
COMMERCIAL HAND BLENDERS - XM RANGE



# IMMERSION BLENDER & WHISK COMBO MB-51 120/50-60/1 USA

Professional hand blender and beater. 1.1 Hp.



P/N. 3030831

## SPECIFICATIONS

Total loading: 1.1 Hp  
Electrical supply: 120 V / 50-60 Hz / 1 ~  
(4.1 A)  
Plug: --

### Liquidiser function

Maximum recipient capacity: 85 qt.  
Motor speed: 1500 - 12000 rpm  
Blade diameter: 2.36 "  
Blade guard diameter: 4 "  
Liquidising arm length: 16.7 "  
Total length: 30.1 "

### Whisk function

Motor speed: 200 - 1500 rpm  
Capacity (egg whites): 2 - 80  
Revolving arm length: 15.94 "  
Total length (with revolving arm): 29.37 "

Net weight: 10.3 lbs.

Noise level (1m.): <80 dB(A)

### Crated dimensions

22.6 x 17.9 x 5.1 "  
Gross weight: 13.9 lbs.

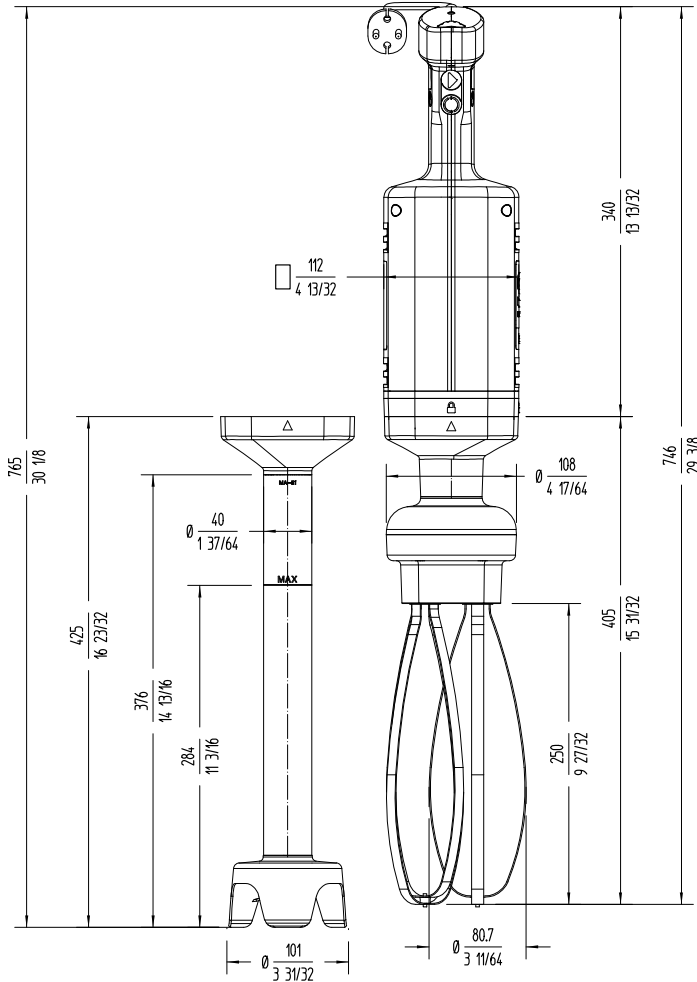

DYNAMIC PREPARATION  
COMMERCIAL HAND BLENDERS - XM RANGE

**sammic** | www.sammic.us  
Food Service Equipment Manufacturer

usa@sammic.com phone +1 (224) 307-2232  
1225 Hartrey Avenue toll free +1 844 275 3848  
60202-1056 Evanston, IL



Project	Date
Item	Qty
Approved	

product sheet  
updated 09/24/20