



# SMARTVIDE 5 120/60/1

1.6 Hp / 1200 W. Maximum capacity: 30 lt./ 8 gal.



P/N. 1180103



## FEATURES AND BENEFITS

**Portable precision cooker with stirrer for up to 30 lt. / 8 gal. containers. Designed for chefs, developed with chefs.**

- ✓ The thick stainless steel, robust construction guarantees commercial performance. The front panel and the grip are made of fiberglass-reinforced polyamide.
- ✓ SmartVide guarantees cooking at a **precisely controlled temperature** while preserving the quality of the product, enhancing flavor and texture. Equipped with a highly precise temperature control system to obtain extremely consistent results.
- ✓ Allows cooking food in their own juice and using this juice immediately after cooking to **enhance flavors**.
- ✓ Marinates and macerates an ingredient in **half the time**.
- ✓ **Infuses and flavors** oil, fat or other products applying the controlled temperature technique.
- ✓ Increases **profits** due to lack of product shrink.
- ✓ Requires **very little hands-on time**, allowing the Chef to do other tasks while the product is being cooked. Just program temperature and time, SmartVide will do the rest. 4 buttons and a full-color TFT display that offers **all the information at a glance** makes operation a child's play.
- ✓ SmartVide5 is **portable**: thanks to their ergonomic handle, SmartVide5 can be taken from a container to another easily. Additionally, the optional bag allows easy transport - wherever the Chef goes.
- ✓ **HACCP-ready**: thanks to Bluetooth connectivity, it is possible to export or print cooking results at the end of each cycle.
- ✓ **Your appliance, always updated**: free firmware update, no matter where the appliance is.

## SALES DESCRIPTION

Commercial high-precision sous-vide cooker. Reliable, user-friendly, portable.

Interchangeable between °C and °F.

- ✓ Bluetooth connectivity.
- ✓ HACCP-ready.
- ✓ Optional core probe.
- ✓ Firmware update.

## ACCESSORIES

- Needle Probe for sous-vide cookers
- SmartVide transport bag
- Probe Foam Seal
- Smooth bags for sous-vide cooking
- Insulated tank for SmartVide immersion circulator
- Lid for SmartVide
- Floating balls for SmartVide



**sammic** | www.sammic.us  
Food Service Equipment Manufacturer

usa@sammic.com  
1225 Hartrey Avenue  
60202-1056 Evanston, IL

phone +1 (224) 307-2232  
toll free +1 844 275 3848



Project	Date
Item	Qty
Approved	

FOOD PRESERVATION AND SOUS-VIDE  
SOUS-VIDE COOKERS

product sheet  
updated 12/30/19



# SMARTVIDE 5 120/60/1

1.6 Hp / 1200 W. Maximum capacity: 30 Lt./ 8 gal.



P/N. 1180103

## SPECIFICATIONS

### Temperature

Display precision: 0.1 °F

Range: 41 °F - 203 °F

Permissible ambient temperature: 41 °F - 104 °F

### Time

Resolution: 1 '

Cycle duration: 1 ' - 99 h

### General features

Maximum recipient capacity: 8 gal.

Total loading: 1.6 Hp

Electrical supply: 120 V / 50-60 Hz / 1 ~ (10 A)

Plug: USA

Submersible part dimensions: 4.6 " x 3.7 " x 5.8 "

External dimensions (WxDxH): 4.6 " x 5 " x 13 "

Net weight: 6.8 lbs.

### Crated dimensions

16.1 x 7.3 x 11.2 "

Gross weight: 11.0 lbs.

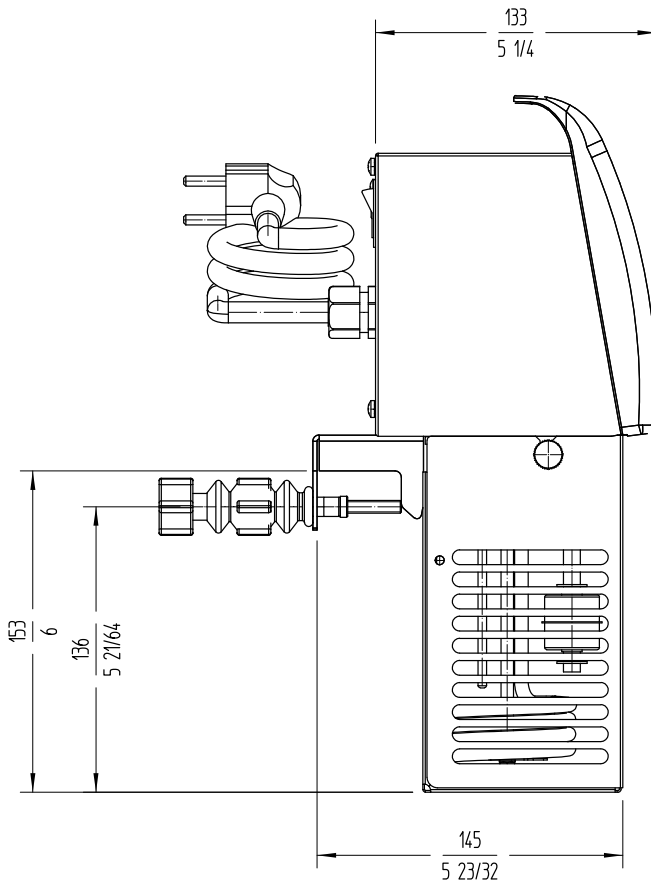
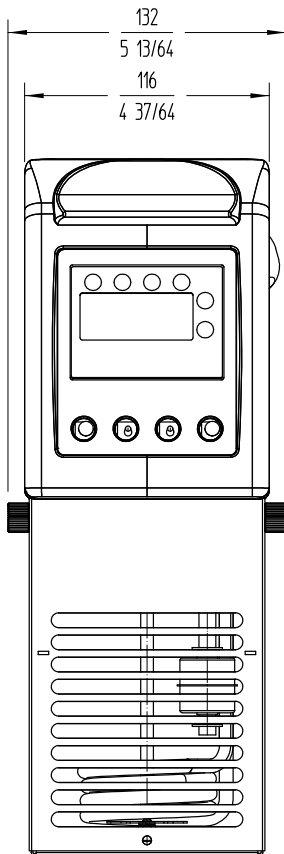

FOOD PRESERVATION AND SOUS-VIDE  
SOUS-VIDE COOKERS

**sammic** | www.sammic.us  
Food Service Equipment Manufacturer

usa@sammic.com  
1225 Hartrey Avenue  
60202-1056 Evanston, IL

phone +1 (224) 307-2232  
toll free +1 844 275 3848



Project

Date

Item

Qty

Approved

product sheet  
updated 12/30/19