



[COMING SOON] HAND BLENDER XM-21

Professional immersion blender. 0.41 Hp.



Maximum comfort for the user

- ✓ Compact design: logical and manageable size.
- ✓ Ergo-design & bi-mat-grip: external casing made in two materials for an ergonomic hold. Anti-slip grip. Optimum inclination of handle, minimising fatigue.
- ✓ Click-on-arm: detachable arm with fast and secure closure.
- ✓ Hood designed to avoid splashes.
- ✓ Intuitive use: very simple operation. Warning light when the machine is connected to the mains.

Built to last

- ✓ Professional performance: capable of carrying out prolonged work without the casing overheating.
- ✓ Life-plus: equipped with a motor which has passed all of the most demanding usage tests.
- ✓ Studied geometry: casing designed to avoid rolling and falling.
- ✓ Easy to clean: detachable arm, can be cleaned under the tap.
- ✓ Approved by NSF: guaranteed safety and hygiene.

INCLUDES

- ✓ Variable speed motor block.
- ✓ MA-21 mixer arm.

ACCESSORIES

- Mixer arms MA-20
- Whisk BA-20



SALES DESCRIPTION

Variable speed motor block.

9.84" detachable arm.

Designed for continuous use in recipients of up to 13qt.

All-in-one

- ✓ Professional hand blender designed for carrying out different preparations without the need for add-on tools.
- ✓ Professional Y-blade, made from tempered steel and with a long-duration cutting edge.
- ✓ Vario-speed: variable speed.
- ✓ Designed to work in recipients of up to 12 litres.



sammic | www.sammic.us
Food Service Equipment Manufacturer

usa@sammic.com
1225 Hartrey Avenue
60202-1056 Evanston, IL

phone +1 (224) 307-2232
toll free +1 844 275 3848



Project	Date
Item	Qty
Approved	

product sheet
updated 08/03/20

DYNAMIC PREPARATION
COMMERCIAL HAND BLENDERS - XM RANGE



[COMING SOON] HAND BLENDER XM-21

Professional immersion blender. 0.41 Hp.



SPECIFICATIONS

Total loading: 0.41 Hp
 Maximum recipient capacity: 13 qt.
 Motor speed: 1500 - 15000 rpm
 : 2 "
 Blade guard diameter: 3.23 "

Length

Liquidising arm length: 9.84 "
 Total length: 20.24 "

Net weight: 5.1 lbs.
 Noise level (1m.): <80 dB(A)

Crated dimensions

17.3 x 14.8 x 4.1 "
 Gross weight: 6.6 lbs.

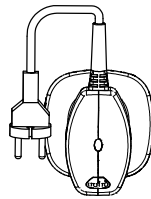
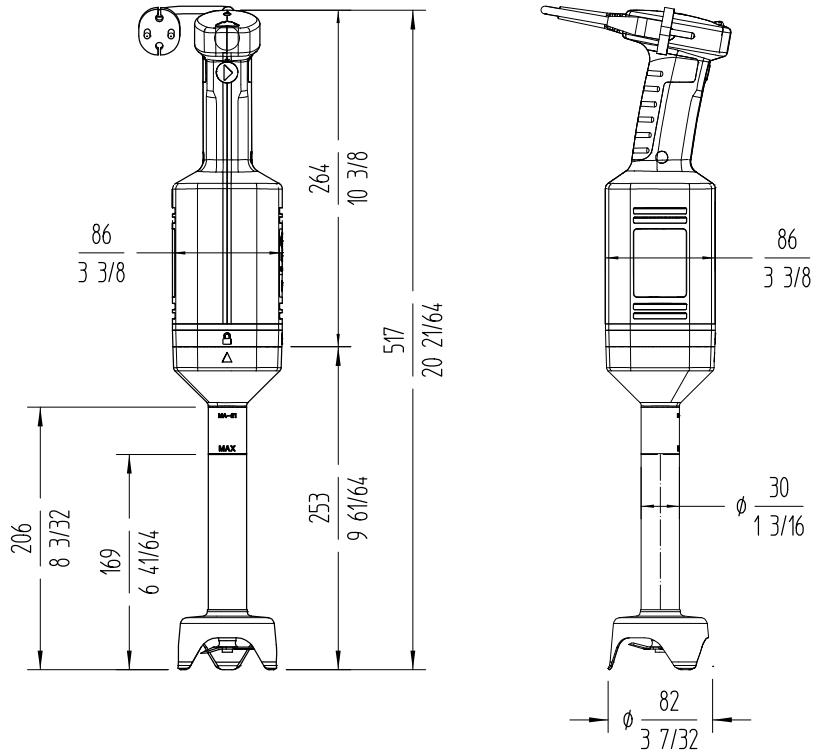

AVAILABLE MODELS

* Ask for special versions availability

sammic www.sammic.us Food Service Equipment Manufacturer usa@sammic.com phone +1 (224) 307-2232 1225 Hartrey Avenue toll free +1 844 275 3848 60202-1056 Evanston, IL		Project	Date
		Item	Qty
		Approved	

DYNAMIC PREPARATION
COMMERCIAL HAND BLENDERS - XM RANGE

product sheet
updated 08/03/20