



IMMERSION BLENDER XM-32 120/50-60/1 USA

Professional immersion blender. 0.54Hp.



P/N. 3030797



Built to last

- ✓ Professional performance: capable of carrying out prolonged work without the casing overheating.
- ✓ Life-plus: equipped with a motor which has passed all of the most demanding usage tests.
- ✓ Studied geometry: casing designed to avoid rolling and falling.
- ✓ Easy to clean: detachable arm, can be cleaned under the tap.
- ✓ Approved by NSF: guaranteed safety and hygiene.

INCLUDES

- ✓ Fixed speed motor block.
- ✓ Wall mount.
- ✓ MA-32 mixer arm.

ACCESSORIES

- Mixer arms MA-30

SALES DESCRIPTION

Fixed speed motor block.
14.41" detachable arm.
Designed for continuous use in recipients of up to 48qt.

All-in-one

- ✓ Professional hand blender designed for carrying out different preparations without the need for add-on tools.
- ✓ Professional Y-blade, made from tempered steel and with a long-duration cutting edge.
- ✓ Fixed speed.
- ✓ Designed to work in recipients of up to 45 litres.

Maximum comfort for the user

- ✓ Compact design: logical and manageable size.
- ✓ Ergo-design & bi-mat-grip: external casing made in two materials for an ergonomic hold. Anti-slip grip. Optimum inclination of handle, minimising fatigue.
- ✓ Click-on-arm: detachable arm with fast and secure closure.
- ✓ Hood designed to avoid splashes.
- ✓ Intuitive use: very simple operation. LED warning light in two colours to indicate the status of the machine.
- ✓ Possibility of continuous operation.



sammic | www.sammic.us
Food Service Equipment Manufacturer

usa@sammic.com
1225 Hartrey Avenue
60202-1056 Evanston, IL

phone +1 (224) 307-2232
toll free +1 844 275 3848



Project	Date
Item	Qty
Approved	

DYNAMIC PREPARATION
COMMERCIAL HAND BLENDERS - XM RANGE

product sheet
updated 09/24/20



IMMERSION BLENDER XM-32 120/50-60/1 USA

Professional immersion blender. 0.54Hp.



P/N. 3030797

SPECIFICATIONS

Total loading: 0.54 Hp
 Maximum recipient capacity: 48 qt.
 Motor speed: 12000 rpm
 Blade diameter: 2.17 "
 Blade guard diameter: 3.6 "
 Electrical supply: 120 V / 50-60 Hz / 1 ~
 (3.5 A)
 Plug: --

Length

Liquidising arm length: 14.41 "
 Total length: 26.54 "

Net weight: 7.85 lbs.
 Noise level (1m.): <80 dB(A)

Crated dimensions

17.9 x 18.7 x 4.6 "
 Gross weight: 10.0 lbs.

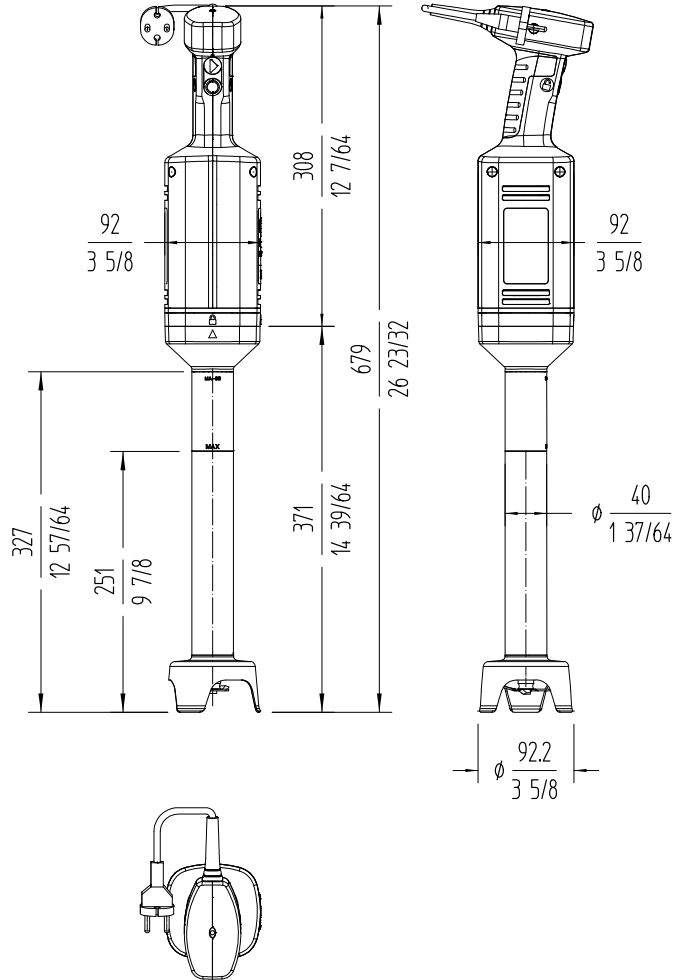

DYNAMIC PREPARATION
COMMERCIAL HAND BLENDERS - XM RANGE

sammic | www.sammic.us
 Food Service Equipment Manufacturer

usa@sammic.com phone +1 (224) 307-2232
 1225 Hartrey Avenue toll free +1 844 275 3848
 60202-1056 Evanston, IL



Project	Date
Item	Qty
Approved	

product sheet
updated 09/24/20