



# IMMERSION BLENDER XM-51 120/50-60/1 USA

Professional immersion blender. 1.1 Hp.

P/N. 3030825



### Maximum comfort for the user

- ✓ Logical and manageable size.
- ✓ Ergo-design & bi-mat-grip: external casing made in two materials for an ergonomic hold. Anti-slip grip. Optimum inclination of handle, minimising fatigue.
- ✓ Click-on-arm: detachable arm with fast and secure closure.
- ✓ Hood designed to avoid splashes.
- ✓ Intuitive use: very simple operation. LED warning light in two colours to indicate the status of the machine.
- ✓ Possibility of continuous operation.

### Built to last

- ✓ Professional performance: capable of carrying out prolonged work without the casing overheating.
- ✓ Life-plus: equipped with a motor which has passed all of the most demanding usage tests.
- ✓ Studied geometry: casing designed to avoid rolling and falling.
- ✓ Easy to clean: detachable arm, can be cleaned under the tap.
- ✓ Approved by NSF: guaranteed safety and hygiene.

### INCLUDES

- ✓ Fixed speed motor block.
- ✓ MA-51 mixer arm.

### ACCESSORIES

- Mixer arms MA-50



## SALES DESCRIPTION

Fixed speed motor block.

16.70" detachable arm.

Designed for continuous use in recipients of up to 85qt.

### All-in-one

- ✓ Professional hand blender designed for carrying out different preparations without the need for add-on tools.
- ✓ Professional Y-blade, made from tempered steel and with a long-duration cutting edge.
- ✓ Fixed speed.
- ✓ Designed to work in recipients of up to 80 litres.



**sammic** | www.sammic.us  
Food Service Equipment Manufacturer

usa@sammic.com  
1225 Hartrey Avenue  
60202-1056 Evanston, IL

phone +1 (224) 307-2232  
toll free +1 844 275 3848



Project	Date
Item	Qty
Approved	



DYNAMIC PREPARATION  
COMMERCIAL HAND BLENDERS - XM RANGE

product sheet  
updated 09/02/20



# IMMERSION BLENDER XM-51 120/50-60/1 USA

Professional immersion blender. 1.1 Hp.



P/N. 3030825

## SPECIFICATIONS

Total loading: 1.1 Hp  
 Maximum recipient capacity: 85 qt.  
 Motor speed: 12000 rpm  
 Blade diameter: 2.36 "  
 Blade guard diameter: 4 "  
 Electrical supply: 120 V / 50-60 Hz / 1 ~  
 (4.1 A)  
 Plug: [v:enchufe]

### Length

Liquidising arm length: 16.7 "  
 Total length: 30.1 "

Net weight: 10.25 lbs.  
 Noise level (1m.): <80 dB(A)

### Crated dimensions

22.6 x 17.9 x 5.1 "  
 Gross weight: 11.5 lbs.

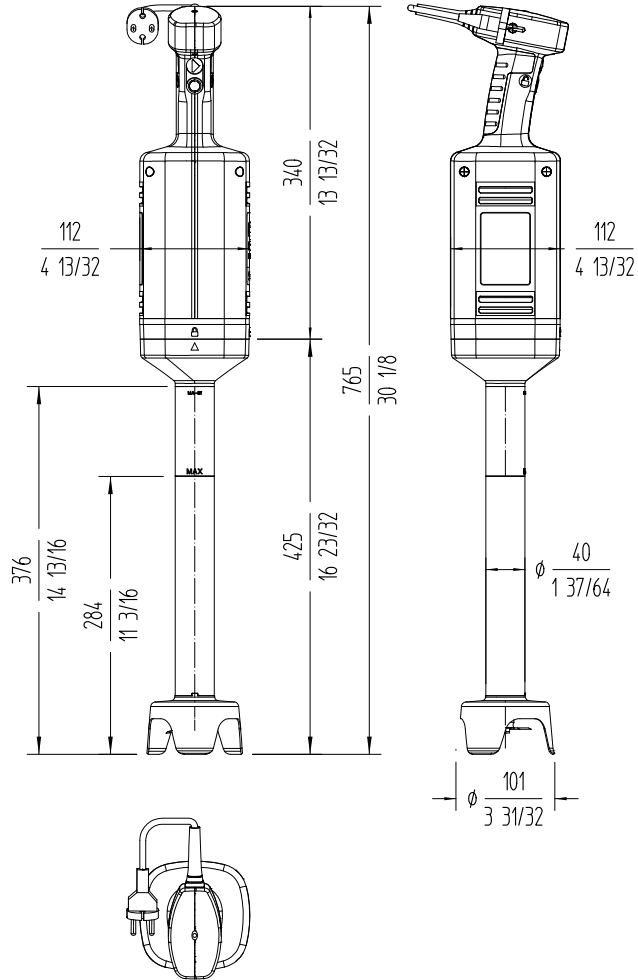

DYNAMIC PREPARATION  
COMMERCIAL HAND BLENDERS - XM RANGE

**sammic** | www.sammic.us  
 Food Service Equipment Manufacturer

usa@sammic.com phone +1 (224) 307-2232  
 1225 Hartrey Avenue toll free +1 844 275 3848  
 60202-1056 Evanston, IL



Project	Date
Item	Qty
Approved	

product sheet  
updated 09/02/20