



[COMING SOON] BLENDER B-30

Professional beater. 0.54 Hp.



- ✓ Studied geometry: casing designed to avoid rolling and falling.
- ✓ Easy to clean: detachable arm, can be cleaned under the tap.
- ✓ Approved by NSF: guaranteed safety and hygiene.

INCLUDES

- ✓ Variable speed motor block
- ✓ Whisk BA-30.
- ✓ Wall mount.

ACCESSORIES

- Motor unit MM-30
- Motor unit MM-30V

SALES DESCRIPTION

Variable speed motor block.
Whisk with capacity for 2 to 50 egg whites.

Professional performance

- ✓ Vario-speed: variable speed.
- ✓ Beater with capacity for 2 to 50 egg whites.

Maximum comfort for the user

- ✓ Compact design: logical and manageable size.
- ✓ Ergo-design & bi-mat-grip: external casing made in two materials for an ergonomic hold. Anti-slip grip. Optimum inclination of handle, minimising fatigue.
- ✓ Click-on-arm: detachable arm with fast and secure closure.
- ✓ Intuitive use: very simple operation. LED warning light in two colours to indicate the status of the machine.
- ✓ Possibility of continuous operation.

Built to last

- ✓ Professional performance: capable of carrying out prolonged work without the casing overheating.
- ✓ Life-plus: equipped with a motor which has passed all of the most demanding usage tests.



sammic | www.sammic.us
Food Service Equipment Manufacturer

usa@sammic.com phone +1 (224) 307-2232
1225 Hartrey Avenue toll free +1 844 275 3848
60202-1056 Evanston, IL



Project	Date
Item	Qty
Approved	

DYNAMIC PREPARATION
COMMERCIAL HAND BLENDERS - XM RANGE

product sheet
updated 09/24/20



[COMING SOON] BLENDER B-30

Professional beater. 0.54 Hp.



SPECIFICATIONS

Total loading: 0.54 Hp
 Motor speed: 200 - 1500 rpm
 Capacity (egg whites): 2 - 50
 Length
 Revolving arm length: 15.6 "
 Total length (with revolving arm): 27.7 "
 Net weight: 7.74 lbs.
 Noise level (1m.): <80 dB(A)

Crated dimensions

17.9 x 18.7 x 4.6 "
 Gross weight: 9.9 lbs.

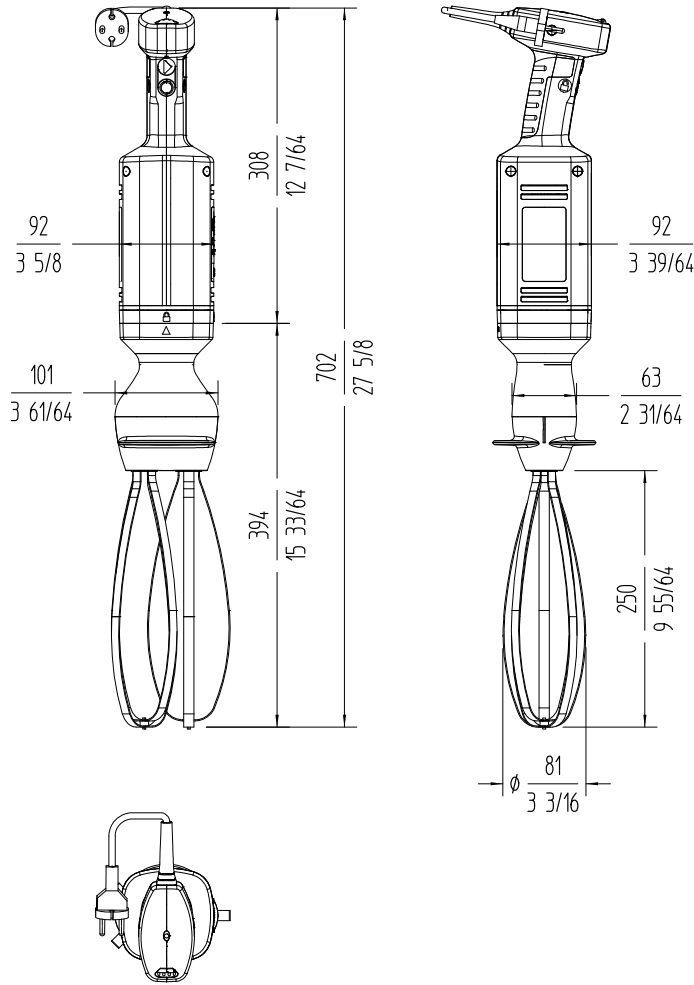

DYNAMIC PREPARATION
COMMERCIAL HAND BLENDERS - XM RANGE

AVAILABLE MODELS

3030807 Beater B-30 120/50-60/1 USA

* Ask for special versions availability

sammic | www.sammic.us
 Food Service Equipment Manufacturer

usa@sammic.com phone +1 (224) 307-2232
 1225 Hartrey Avenue toll free +1 844 275 3848
 60202-1056 Evanston, IL



Project	Date
Item	Qty
Approved	

product sheet
updated 09/24/20