

SINGLE KEG BEER DISPENSER

Perlick Features

- Front vented compressor.
- Stainless steel exterior.
- Quiet-running high efficiency compressor.
- Two inch thick foamed-in-place insulation saves on energy costs and adds strength.
- Efficient, balanced refrigeration system.
- High strength polyethylene reinforced door sill that absorbs keg impact without sagging.
- Interior floor drain with bottom or side access.
- Self-closing door with heavy-duty stainless steel hinges opens wide for easier keg access.
- Heavy-duty locking casters and beer waste bottle. (Portable model)
- Door locks standard on all models.
- Compartment for optional #5 CO2 cylinder and regulator.
- Door and grille available in stainless steel or black vinyl coated.

MODEL NOS.

- DP32B
- DP32S
- DS32B
- DS32S

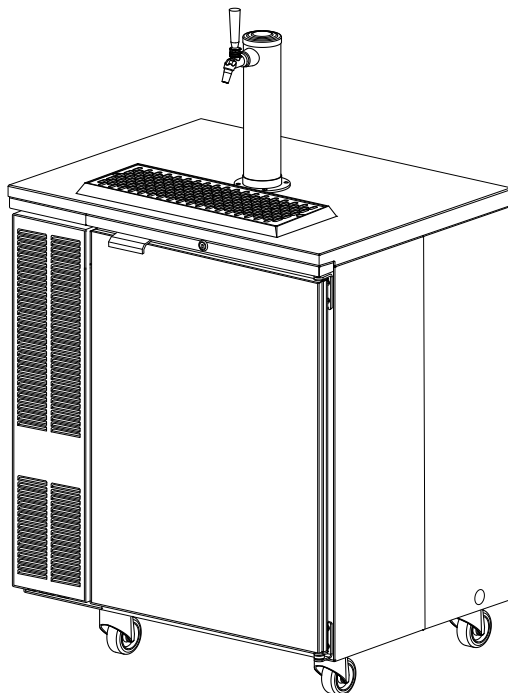

DP32

Shown with Optional
1 Faucet Draft Arm.

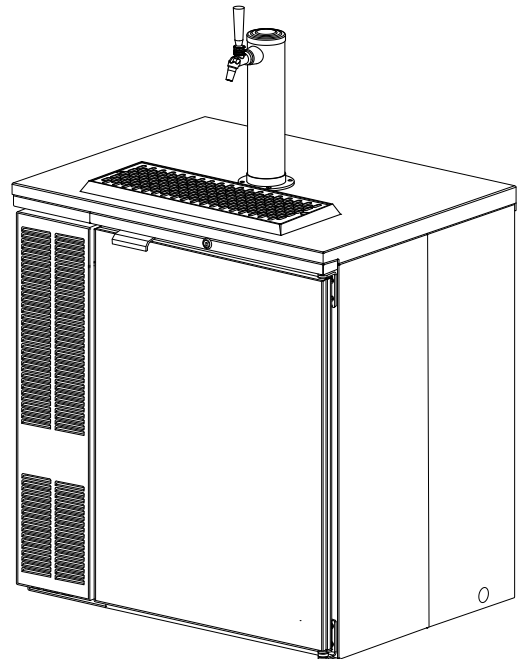

DS32



8300 West Good Hope Road • Milwaukee, WI 53223 • Phone 414-353-7060 • Fax 414-353-7069
Toll Free 800-558-5592 • E-Mail: Perlick@Perlick.com • www.Perlick.com

Form No. 072505
Rev. 05.24.10

Sizes and Specifications Single Keg Beer Dispensers

Job _____
 Area _____
 Item No. _____
 Model No. _____

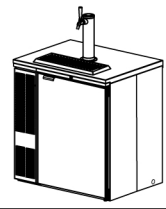
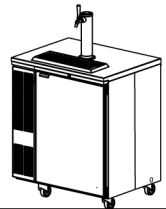

CABINET STYLE		PORTABLE	UNDERBAR
		MODEL NOS.	
DOOR FINISH	Black	DP32B	DS32B
	Stainless Steel	DP32S	DS32S
CABINET DIMENSIONS	Length - Inches (mm)	32" (814)	32" (814)
	Depth - Inches (mm)	24 3/4" (629)	24 3/4" (629)
	Height - Inches (mm)	34 1/2" (876)	34 1/2" (876)
NUMBER OF DOORS		1	1
HALF BARREL CAPACITY		1	1
DISPENSING HEAD		Customer Choice	
AMPS		2.7	2.7
SHIP WT Lbs. (kg)		222 (101)	216 (98)
INTERIOR	Door pan and ceiling: High strength polystyrene. Door sill: High strength polyethylene. Floor pan: Stainless steel. Walls: Galvanized steel.		
EXTERIOR	Stainless steel top, back, sides and front. Galvanized bottom. Stainless steel pull tab handle. Right hinged door standard from factory. Door hinging is reversible. Black models: Door and grille are black vinyl coated steel. Stainless models: Door and grille are stainless steel.		
REFRIGERATION	R-134A capillary tube-type. Aluminum fin and copper tube evaporator coil. Adjustable temperature control. Self-defrosting.		
VENTILATION	Front vented.		
ELECTRICAL	115V, 60Hz., 1 phase AC. Furnished with 3-prong, 6 foot NEMA 5-15P cord. Contact Perlick for other voltage/ frequency requirements.		
PLUMBING	Evaporator condensate is removed automatically. Floor drain with 3/4" NPT at right end or 1" NPS out bottom come plugged from factory. Portable model: Includes beer waste bottle plumbed to drainer. Underbar model: Includes vinyl tube to plumb beer drainer to floor drain.		
OPTIONAL ACCESSORIES	• Leg set • Caster sets		

NOTE: This equipment is intended for the storage and display of non-potentially-hazardous bottled or canned products only.

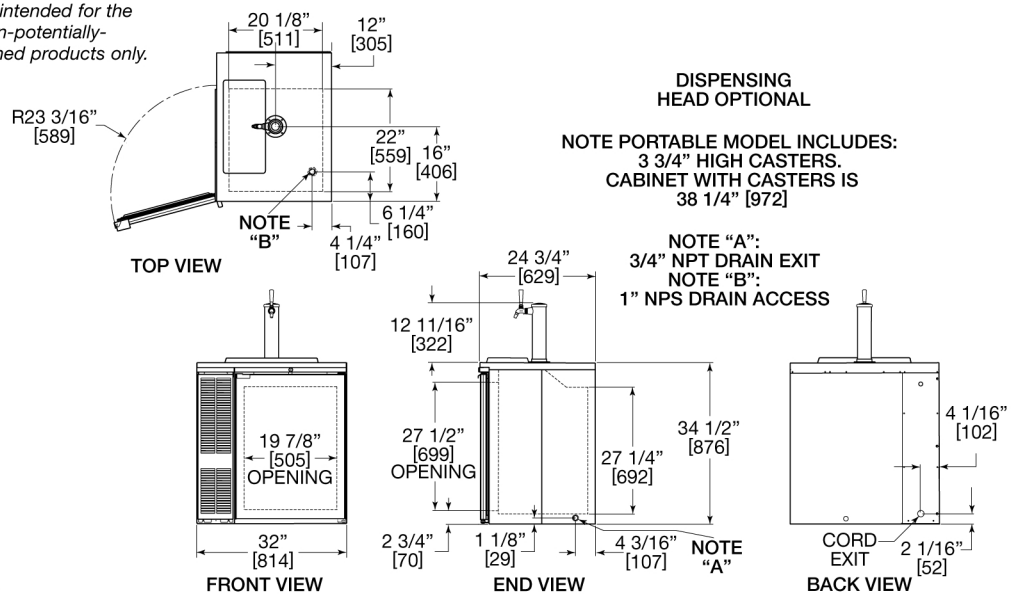

8300 West Good Hope Road • Milwaukee, WI 53223 • Phone 414-353-7060 • Fax 414-353-7069
 Toll Free 800-558-5592 • E-Mail: Perlick@Perlick.com • www.Perlick.com