



IP 30 M



IP 50 M

Meat mixers - bench / floor



YouTube



IP 30 M



IP 50 M
(shown with Set of 4 s/steel legs w/ brake casters option)

- 60 and 105 lbs. single paddle mixers allow for a fast, homogenous yet gentle mix of a variety of products from sausage meat to potato salad, coleslaw and sandwich fillings - with a great sales appeal and longer shelf-life result
- Complete stainless steel construction
- Forward and reverse mixing action allows for more control over the most delicate products
- Exclusive side opening for easy product discharge from the tub, paddle removal and faster clean-up

Features

Technical

- Completely made from stainless steel.
- Stainless steel paddle rotates for a thorough mixing and a faster kneading.
- The openable side lid facilitates easy product emptying, fast cleaning and maintenance.

Safety

- A safety interlock stops the machine when opening the lid.
- Overload and no volt release protection

Sanitary

- Removable paddle for an easy and accurate cleaning.

Optional

- Set of 4 s/steel legs with brake casters

Specifications

Motor: 1.15 Hp (850W), 3.7A, fan cooled.
Electrical: 220V AC, 60Hz, Single Phase.
Plug and Cord: Attached, flexible, 4 wire (3PH+1G) SJT 14 AWG, 6'4" long cord.
Controls: ON/OFF/REV stainless steel keypad, IP 67 waterproof protection. No voltage release





IP 30 M

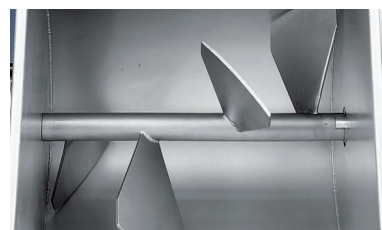

IP 50 M



ON / OFF / REV stainless steel keypad
IP 67 waterproof protection
No voltage release

Easy and fast breakdown for unloading and cleaning

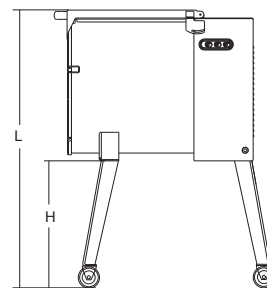
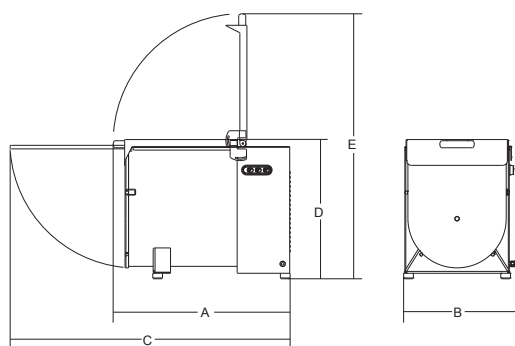

Set of 4 s/steel legs with
brake casters

	Power	Power source	Tank dimensions	Capacity	A	B	C	D	E	H	L	Net weight	Shipping	Gross weight
	watt/Hp		inch.	lbs.	inch.	inch.	inch.	inch.	inch.	inch.	inch.	lbs.	inch.	lbs.
IP 30 M	850/1.15	220V 60Hz 1-phase	11 ¹³ / ₁₆ " x 15 ³ / ₄ "	60	26 ³ / ₄ "	14 ³ / ₈ "	44 ¹ / ₈ "	20 ⁷ / ₈ "	38 ³ / ₈ "	17 ⁵ / ₁₆ "	37"	108	30" x 26" x 29"	130
IP 50 M	850/1.15	220V 60Hz 1-phase	16 ¹ / ₈ " x 18 ⁷ / ₈ "	105	29 ¹ / ₂ "	18 ⁵ / ₁₆ "	49 ³ / ₁₆ "	23 ⁷ / ₁₆ "	44 ¹ / ₈ "	17 ⁵ / ₁₆ "	39 ³ / ₄ "	130	33" x 34" x 33"	163