

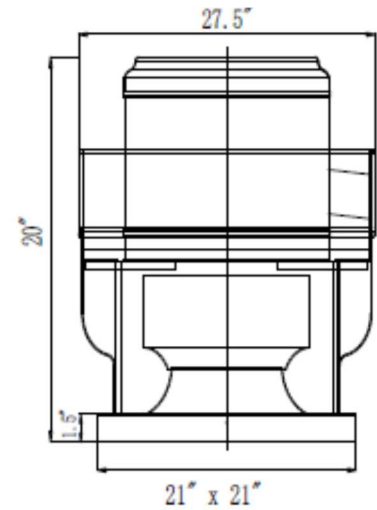

# Direct Drive Centrifugal Exhaust Fan

## Features:

- UL-705 Certification for Restaurant and general ventilation applications
- Heavy Gauge Aluminum Housing
- Centrifugal Backward Inclined Aluminum Impeller
- 120 or 240 voltage single phase
- Speed Controller
- Factory Disconnect
- Thermally Protected Direct Drive TEFC Motor
- Integral Grease Spout



Fan Performance						Motor Information			
Model	CFM*	ESP	dB(A)	Fan Speed	Weight (lbs)	Motor HP	BHP	Voltage	Motor AMPS
SH-EXH-RDU08	2450	0.10	63.5	1720	55	0.50	.37	115/1	5.6
								230/1	2.8

\*Sea level, 70 degree F ambient

Noise										
63	125	250	500	1K	2K	4K	8K	LwA	dBA(1m)	dBA(3m)
93	88	86	82	78	76	74	82	85	73	63.5

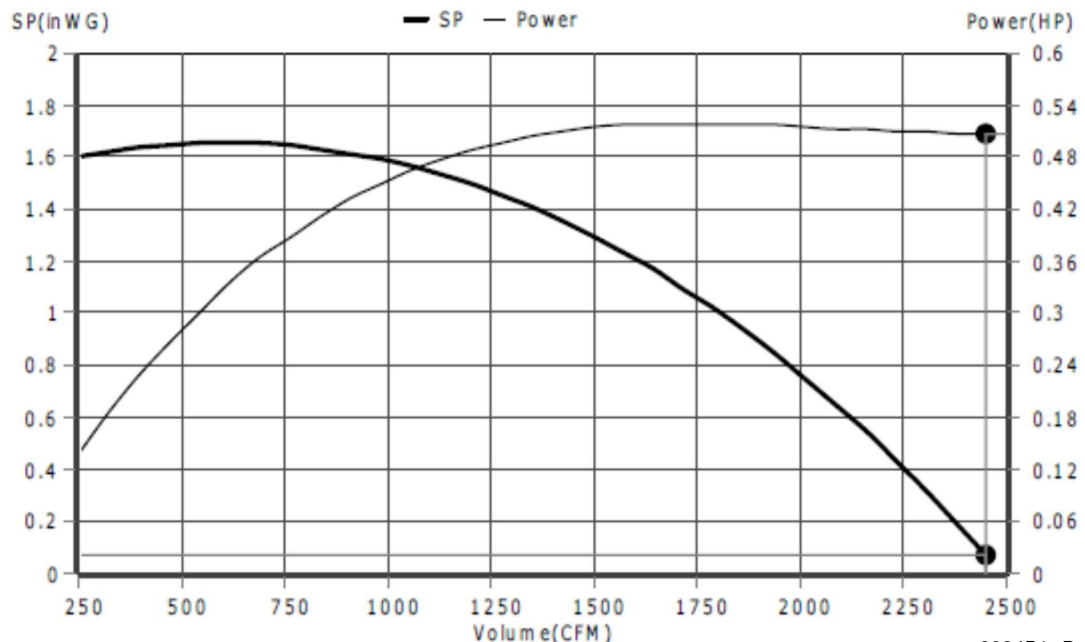

0924R1 Data Subject to Change