



# TRUE FOOD SERVICE EQUIPMENT, INC.

St. Charles Industrial Center • P.O. Box 970 • O'Fallon, Missouri 63366  
(636)240-2400 • FAX (636)272-2408 • (800)325-6152 • www.truemfg.com

Project Name: \_\_\_\_\_

AIA #

Location: \_\_\_\_\_

SIS #

Item #: \_\_\_\_\_ Qty: \_\_\_\_\_

Model #: \_\_\_\_\_

## T-Series Glass Door Models



**T-23G**

*TRUE, rated the #1 brand in America.*

## Glass Door Reach-In Refrigerators (single door models)

T-12G,  T-19G,  T-23G

### SPECIFICATIONS / FEATURES

#### CABINET CONSTRUCTION:

- 300 series stainless steel front grill, shroud. Anodized quality aluminum exterior ends and back.
- NSF approved, white vinyl coated aluminum and 300 series stainless floor with coved corners.
- Barrel lock standard for each door (excluding T-12G). Locks keyed alike. Dial exterior mounted temperature monitor.
- Cabinet mounted on a welded, galvanized frame rail, painted for additional corrosion protection. Frame rail fitted with 4" diameter castors, front castors include brakes (not available for the T-12G; 2 1/2" diameter castors standard for T-19G).

#### DOORS:

- Triple pane thermal insulated glass assembly within extruded aluminum frame, with reinforcing backing plates in each corner. Glass assembly replaceable without removing the door from hinges.
- Lifetime guaranteed adjustable torsion type closure system with aluminum block supports. The face of each door fitted with a 15" long handle of same material as door frame.

#### INSULATION:

- Entire cabinet structure insulated using foamed-in-place CFC free polyurethane foam.

#### SHELVING:

- Adjustable vinyl coated wire shelves (3 per section). Shelves capable of supporting up to 250 lbs.
- Full height shelf support pilasters, with double oblong holes on 1/2" centers. Pilasters made of the same material as cabinet interior. Four (4) chrome plated, stainless steel shelf clips to be included for each shelf.

#### LIGHTING:

- Fluorescent interior lighting, completely inter-wired to light switch.

#### REFRIGERATION SYSTEM:

- Refrigeration system factory balanced using CFC free 134A refrigerant.
- Bottom mounted condensing unit - easy access for maintenance.
- Factory pre-engineered capillary tube system with oversized condenser and evaporator to reduce product pull down time and to consistently maintain 33°F to 38°F interior cabinet temperature. (non-adjustable capillary tube system superior to problematic expansion valve)
- Evaporator - epoxy coated at the time of manufacture to eliminate the potential of corrosion.

#### ELECTRICAL CHARACTERISTICS:

- Unit completely pre-wired at factory, and ready for final connection to a 115/60/1 phase - 15 amp dedicated outlet. A cord and plug set to be included.
- A sole use circuit is required.



115/60/1  
NEMA-5-15R

#### Also available:

- Top Mounts
- Solid Door Models
- Half and Combination Doors
- Slide Door Models
- Freezers
- All Stainless Steel In / Out
- Heated Cabinet (solid & glass door)

Remote cabinets available 14% off list  
(condensing units supplied by others).  
Consult factory technical service dept. for BTU information.

Specifications subject to change without notice.

Printed in  
U.S.A.



#### APPROVALS:

2/03

Exceptions:



# T-Series: Single Glass Door Reach-In Refrigerators

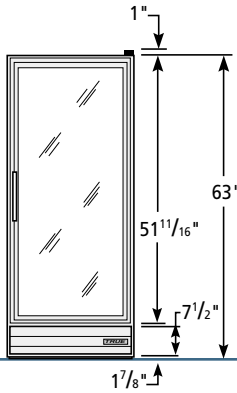
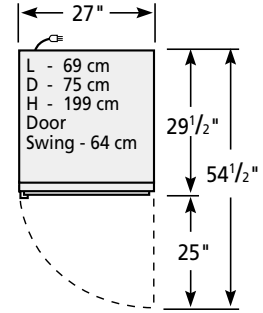
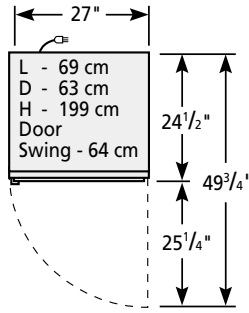
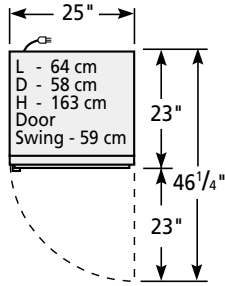

T-12G

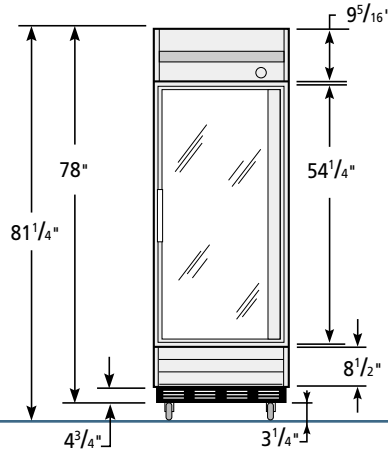

T-19G

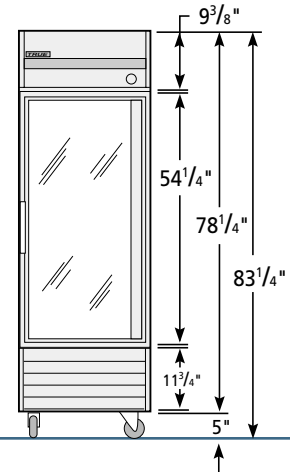

T-23G

## Rough-In Data

Model	Doors	Capacity (Cu. Ft)	# of Shelves	Dimensions (inches)			HP	Volts	PH	Amps	NEMA Config.	Cord Length (feet)	Crated Weight
				L	D‡	H†							
T-12G (1)	1	12	3	25	23	64	1/5	115	1	5.0	5-15	6	258
T-19G (1)	1	19	3	27	24 1/2	78	1/3	115	1	5.5	5-15	9	275
T-23G (1, 2)	1	23	3	27	29 1/2	78 1/4	1/3	115	1	8.0	5-15	9	290

(1) Available with full solid doors

(2) Available with solid half doors, glass half doors & combination solid/glass half doors

† Height does not include 5" for castor height or 6" for optional legs on T-23G;

‡ 3 1/4" castors on T-19G legs available. (T-12G standard with leg levelers, available with optional 2 1/2" diameter castors, legs not available).

‡ Depth does not include 1 3/8" for door handle.

Specifications subject to change without notice.

## Standard Features

- Oversized and balanced, environmentally friendly (134A) refrigeration system - holds 33°F to 38°F.
- 300 series stainless steel front.
- Interior - NSF approved, white vinyl coated aluminum sides and top, 300 series stainless steel floor with coved corners.
- Anodized quality aluminum top, sides and back.
- Triple pane thermal insulated glass doors. Double insulation for greater energy savings. Exterior pane is tempered for safety.
- Exterior mounted temperature monitor.
- Door locks standard (not available for T-12G).
- Magnetic door gaskets
- Adjustable vinyl coated wire shelves.
- Epoxy coated evaporator.
- Fluorescent interior lighting; patented, integrated door light (IDL) standard (excludes T-12G).
- Foamed-in-place high density polyurethane insulation (CFC free).
- T-23G: 4" diameter swivel castors standard equipment - locking castors provided for front set. Legs available.
- T-19G: 2 1/2" diameter castors standard equipment. Legs available.

- T-12G: leg levelers standard.
- Slide out compressor can be serviced easily and accessed by a single repairman.
- 1 year parts & labor warranty (USA)
- 5 year compressor warranty

## Optional Accessories

- T-19G & T-23G available with 6" stainless steel or optional seismic legs.
- Additional shelves available.
- T-12G, T-19G & T-23G available with optional novelty baskets.

Clearance Required For Coolers (USA)		
Sides Inches/mm	Top* Inches/mm	Rear Inches/mm
0/0	1/26	1/26

\* T-12G & 19G only.

Model	Front	Right	Plan	3D
T-12G	TFEY30E	TFEY30S	TFEY30P	TFEY303
T-19G	TFE016E	TFE016S	TFE016P	TFE0163
T-23G	TFEY06E	TFEY06S	TFEY06P	TFEY063



## TRUE FOOD SERVICE EQUIPMENT

