



TRUE FOOD SERVICE EQUIPMENT, INC.

2001 East Terra Lane • P.O. Box 970 • O'Fallon, Missouri 63366
 (636)240-2400 • Fax (636)272-2408 • (800)325-6152 • Intl Fax# (001)636-272-7546
 Parts Dept. (800)424-TRUE • Parts Dept. Fax# (636)272-9471 • www.truemfg.com

Project Name: _____

Location: _____

Item #: _____ Qty: _____

Model #: _____

A/A #

S/S #

Model:
TAC-14GS

Vertical Air Curtains:
Glass Sided Refrigerator



Shown with optional exterior.

TAC-14GS

- ▶ True's air curtain merchandisers are designed with enduring quality that protects your long term investment.
- ▶ Designed using the highest quality materials and components to provide the user with colder product temperatures and lower utility costs in an attractive merchandiser that brilliantly displays food and beverages.
- ▶ Large, open front allows easy access to display levels and places maximum attention on merchandising.
- ▶ Oversized, factory balanced, refrigeration system holds 35°F to 40°F (1.6°C to 4.4°C).
- ▶ Patented reversing condenser fan motors. Fan motors reverse during defrost off cycles to help keep condenser coil free from dirt, dust and debris. Keeping coils clean optimizes the unit's performance providing colder holding temperatures and increased energy efficiency. Regularly scheduled thorough cleaning of coils still recommended.
- ▶ Durable and permanent non-peel or chip black vinyl exterior with white aluminum interior and stainless steel floor and deck pans.
- ▶ Adjustable, heavy duty PVC coated shelves.
- ▶ Entire cabinet structure is foamed-in-place using Ecomate. A high density, polyurethane insulation that has zero ozone depletion potential (ODP) and zero global warming potential (GWP).

ROUGH-IN DATA

Specifications subject to change without notice.
 Chart dimensions rounded up to the nearest 1/8" (millimeters rounded up to next whole number).

Model	Shelves	Cabinet Dimensions (inches) (mm)			HP	Voltage	Amps	NEMA Config.	Cord Length (total ft.) (total m)	Crated Weight (lbs.) (kg)
		L	D	H						
TAC-14GS	3	30 1/4	30 3/8	56 3/8	1/2	115/60/1	13.9	5-20P	6.5	315
		769	772	1432	1/2	230-240/50/1	4.5	▲	1.98	143

▲ Plug type varies by country.



APPROVALS:

AVAILABLE AT:

8/11

Printed in U.S.A.

Model:
TAC-14GS

Vertical Air Curtains: Glass Sided Refrigerator



STANDARD FEATURES

DESIGN

- Designed using the highest quality materials and components to provide the user with colder product temperatures and lower utility costs in an attractive merchandiser that brilliantly displays packaged food and beverages.

REFRIGERATION SYSTEM

- Factory engineered, self-contained, capillary tube system using environmentally friendly (CFC free) 134A refrigerant.
- Time-initiated, time-terminated off cycle defrost system.
- Extra large evaporator coil and condenser balanced with higher horsepower compressor; maintains cabinet temperatures of 35°F to 40°F (1.6°C to 4.4°C) for the best in food preservation.
- Sealed, cast iron, self-lubricating evaporator fan motors.
- Bottom mounted condensing unit positioned for easy maintenance.
- Patented reversing condenser fan motor. Fan motor reverses during defrost off cycles to help keep condenser coil free from dirt, dust and debris. Keeping coils clean optimizes the unit's performance providing colder holding temperatures and increased energy efficiency. Regularly scheduled thorough cleaning of coils still recommended.

CABINET CONSTRUCTION

- Exterior - durable and permanent non-peel or chip black vinyl front and sides with matching black aluminum back.
- Plexiglass lower front and side panels. Durable and break resistant maximizes product visibility.
- Interior - attractive, NSF approved, white aluminum liner. Stainless steel interior floor and deck pans.

- Insulation - entire cabinet structure is foamed-in-place using Ecomate. A high density, polyurethane insulation that has zero ozone depletion potential (ODP) and zero global warming potential (GWP).
- Welded, heavy duty steel frame rail, black powder coated for corrosion protection.
- Frame rail fitted with leg levelers.
- Illuminated exterior sign panel. Variety of sign options available.

SHELVING

- Three (3) adjustable, heavy duty PVC coated wire shelves 25¹/₁₆" L x 17¹/₂" D (653 mm x 445 mm). Four (4) chrome plated shelf clips included per shelf.
- Shelf support pilasters made of same material as cabinet interior; shelves are adjustable on 1/2" (13 mm) increments.

LIGHTING

- Fluorescent interior lighting, safety shielded.
- T8 bulbs and electronic ballast; provides better illumination of product and increased energy efficiency.

MODEL FEATURES

- Perforated interior back wall for more efficient airflow.
- Listed under NSF-7 for the storage and/or display of packaged or bottled product.

ELECTRICAL

- Unit completely pre-wired at factory and ready for final connection to a 115V / 60 Hz single phase, 20 amp dedicated outlet. Cord and plug set included.



115/60/1
NEMA-5-20R

RECOMMENDED OPERATING CONDITIONS

- Designed to operate in an environment where temperature and humidity do not exceed 75°F (24°C) and 55% relative humidity.
- Unit should not be installed near HVAC vents, fans or doorways that will disrupt the air curtain and compromise the function of the cabinet. Unit should not be installed in direct sunlight.
- Model will run most efficiently when completely loaded with product.
- Drain plumbing hookup recommended.
- Please be advised Air Curtain models are substantially louder than standard refrigeration models.

OPTIONAL FEATURES/ACCESSORIES

Upcharge and lead times may apply.

- 230 - 240V / 50 Hz.
- 4" (102 mm) diameter castors (set of 4).
- Variety of sign panels - see our website for the latest color and sign offerings.
- White exterior.
- Stainless steel exterior.
- Black interior liner with black shelves.
- Additional shelves.
- TrueFlex gravity feed organizers.
- TrueTrac 20 oz. (592 ml) organizers.
- TrueTrac 8 oz./10 oz. (237 ml / 296 ml) milk organizers.
- TrueTrac 12 oz. milk organizers.
- Pricing strips.
- Remote cabinets (condensing unit supplied by others; system comes standard with 404A expansion valve and requires R404A refrigerant). Consult factory technical service department for BTU information. All remote units must be hard wired during installation.

PLAN VIEW

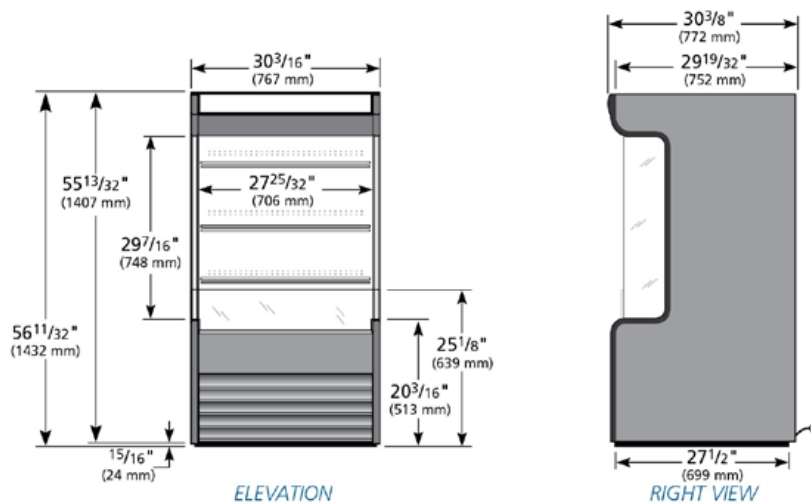

WARRANTY

One year warranty on all parts and labor and an additional 4 year warranty on compressor. (U.S.A. only)

METRIC DIMENSIONS ROUNDED UP TO THE NEAREST WHOLE MILLIMETER

SPECIFICATIONS SUBJECT TO CHANGE WITHOUT NOTICE



Model	Elevation	Right	Plan	3D	Back
TAC-14GS	TFD060E	TFD060S	TFD060P	TFD0603	

TRUE FOOD SERVICE EQUIPMENT

2001 East Terra Lane • P.O. Box 970 • O'Fallon, Missouri 63366 • (636)240-2400 • Fax (636)272-2408 • (800)325-6152 • Intl. Fax# (001)636-272-7546 • www.truefmfg.com

A City Discount