



TRUE FOOD SERVICE EQUIPMENT, INC.

2001 East Terra Lane • O'Fallon, Missouri 63366
 (636)240-2400 • Fax (636)272-2408 • (800)325-6152 • Intl Fax# (001)636-272-7546
 Parts Dept. (800)424-TRUE • Parts Dept. Fax# (636)272-9471 • www.truemfg.com

Project Name: _____

Location: _____

Item #: _____ Qty: _____

Model #: _____

A/A #

S/S #

Model:
TFM-41FL

Horizontal Freezer:
Glass Flat Lid



TFM-41FL

- ▶ True's horizontal freezers are uniquely designed to promote high-profit frozen novelties in high impulse retail traffic areas. Ideal for bolstering incremental sales of frozen merchandise and seasonal specialties.
- ▶ Cold wall, environmentally friendly (134A) refrigeration system. Maintains -10°F (-23.33°C), ideal for both ice cream and frozen food.
- ▶ Exterior - non-peel or chip white laminated vinyl, durable and permanent; with gray mitered plastic top and lid frames.
- ▶ Interior - NSF approved, white aluminum with stainless steel floor.
- ▶ Tempered, hard coated, "Low-E" glass slide lids. Reduces solar heat gain, enhances energy efficiency and minimizes condensation.
- ▶ Locks standard, provide security, prevents theft.
- ▶ Convenient defrost drain.
- ▶ 2½" (64 mm) diameter stem castors.
- ▶ Entire cabinet structure is foamed-in-place using Ecomate. A high density, polyurethane insulation that has zero ozone depletion potential (ODP) and zero global warming potential (GWP).

ROUGH-IN DATA

Specifications subject to change without notice.
 Chart dimensions rounded up to the nearest 1/8" (millimeters rounded up to next whole number).

Model	Lids	Cabinet Dimensions (inches) (mm)			HP	Voltage	Amps	NEMA Config.	Cord Length (total ft.) (total m)	Crated Weight (lbs.) (kg)
		L	D	H*						
TFM-41FL	2	41 3/8	26 1/8	31 5/8	1/4	115/60/1	2.5	5-15P	9	190
		1051	664	804	1/4	230-240/50/1	1.4	▲	2.74	87

* Height does not include 3/4" (83 mm) for castors & 7/8" (23mm) for lid handle.

▲ Plug type varies by country.



APPROVALS:

AVAILABLE AT:

6/12

Printed in U.S.A.

Model:
TFM-41FL

Horizontal Freezer: Glass Flat Lid



STANDARD FEATURES

DESIGN

- True's horizontal freezers are uniquely designed to promote high-profit frozen novelties in high impulse retail traffic areas. Ideal for bolstering incremental sales of frozen merchandise and seasonal specialties.

REFRIGERATION SYSTEM

- Factory engineered, self-contained, capillary tube system using environmentally friendly (CFC free) 134A refrigerant.
- Cold wall refrigeration system. Maintains -10° F (-23.33°C) cabinet temperature, ideal for both ice cream and frozen food.
- Condensing unit is accessed from behind grill on right side; slides out for easy maintenance.
- Manual defrost system; convenient drain located on front of cabinet.

CABINET CONSTRUCTION

- Exterior - non-peel or chip white laminated vinyl, durable and permanent; with gray mitered plastic top and lid frames.

- Interior - attractive, NSF approved, white aluminum liner; non-rust, peel or chip. Stainless steel floor.
- Insulation - entire cabinet structure is foamed-in-place using Ecomate. A high density, polyurethane insulation that has zero ozone depletion potential (ODP) and zero global warming potential (GWP).
- 2 1/2" (64mm) diameter stem castors.

LIDS

- Tempered, hard coated, "Low-E", single pane glass slide lid assemblies. The latest in energy efficient technology; reduces solar heat gain and minimizes condensation.
- Designed for convenient access, fast service and attractive display.
- Lid lock standard.

MODEL FEATURES

- Self-contained, portable system. No plumbing required.
- Low profile design permits easier placement, saves aisle space.
- Interior mounted thermometer.
- NSF-7 compliant for open food product.

ELECTRICAL

- Unit completely pre-wired at factory and ready for final connection to a 115/60/1 phase, 15 amp dedicated outlet. Cord and plug set included.



115/60/1
NEMA-5-15R

OPTIONAL FEATURES/ACCESSORIES

Upcharge and lead times may apply.

- 230 - 240V / 50 Hz.
- Black vinyl exterior.
- Heavy duty novelty baskets (accommodates 3).
- Dividers for novelty baskets.
- Convertible freezer refrigerator.

PLAN VIEW

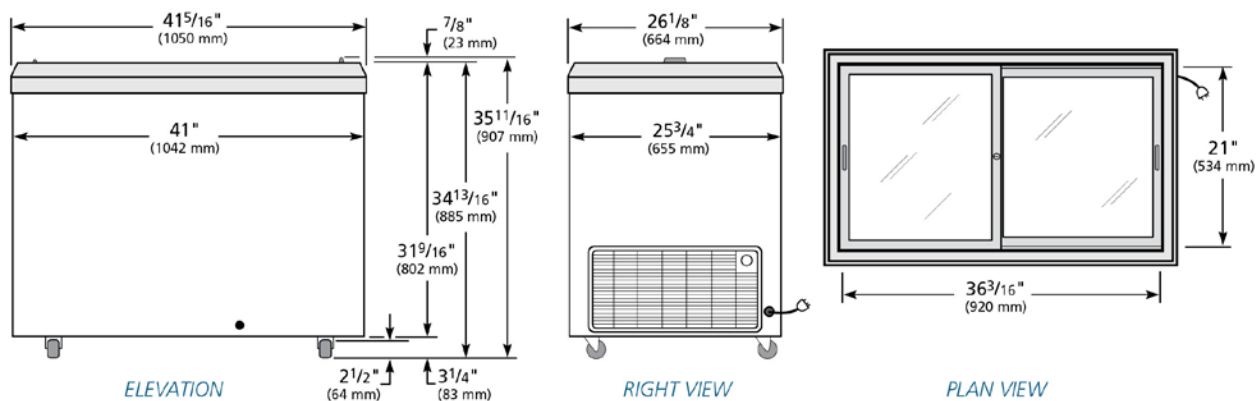

WARRANTY

One year warranty on all parts and labor and an additional 4 year warranty on compressor. (U.S.A. only)

METRIC DIMENSIONS ROUNDED UP TO THE NEAREST WHOLE MILLIMETER

SPECIFICATIONS SUBJECT TO CHANGE WITHOUT NOTICE



Model	Elevation	Right	Plan	3D	Back
TFM-41FL	TFEY79E	TFEY78S	TFEY79P	TFEY793	TFEY79B

TRUE FOOD SERVICE EQUIPMENT

2001 East Terra Lane • O'Fallon, Missouri 63366 • (636)240-2400 • Fax (636)272-2408 • (800)325-6152 • Intl. Fax# (001)636-272-7546 • www.truefmfg.com

A City Discount