



Foodservice Equipment

Job \_\_\_\_\_ Item# \_\_\_\_\_

## 15 lb. Electric Fryer

*TMFE15*

### Standard Features:

- Compact design requiring only 18" of counter space.
- Easy removal 15 lb. lift-out nickel plated steel kettle.
- Immersion-type tubular heating elements rated at 5,500 watts.
- Swing up basket design.
- Snap-action thermostat ranges from 200°F to 375°F.
- High-limit safety thermostat, on-off switch and indicator light.
- Two nickel plated steel mesh side baskets (4"W x 4-3/4"D x 11"L).
- Adjustable 4" legs.



### Applications:

The Toastmaster Electric Countertop Fryer is the most economical and flexible Electric Countertop Fryer in the food service industry. It offers unsurpassed performance, combining a proven control system with Toastmaster quality and durability. They are designed to efficiently fry a wide variety of products by immersion into heated liquefied shortening.

### General Information:

The fryers are equipped with immersion type stainless steel tubular

heating elements which swing up and burn clean pyrolytically in the raised position. The elements configuration surrounds the sides, front, back and bottom of the shortening container. A handle is provided for raising and lowering the heating elements.

### Warranty:

Toastmaster fryers are covered by Toastmaster's one year parts and labor warranty.



T110/0119

# 15 lb. Electric Fryer

TMFE15

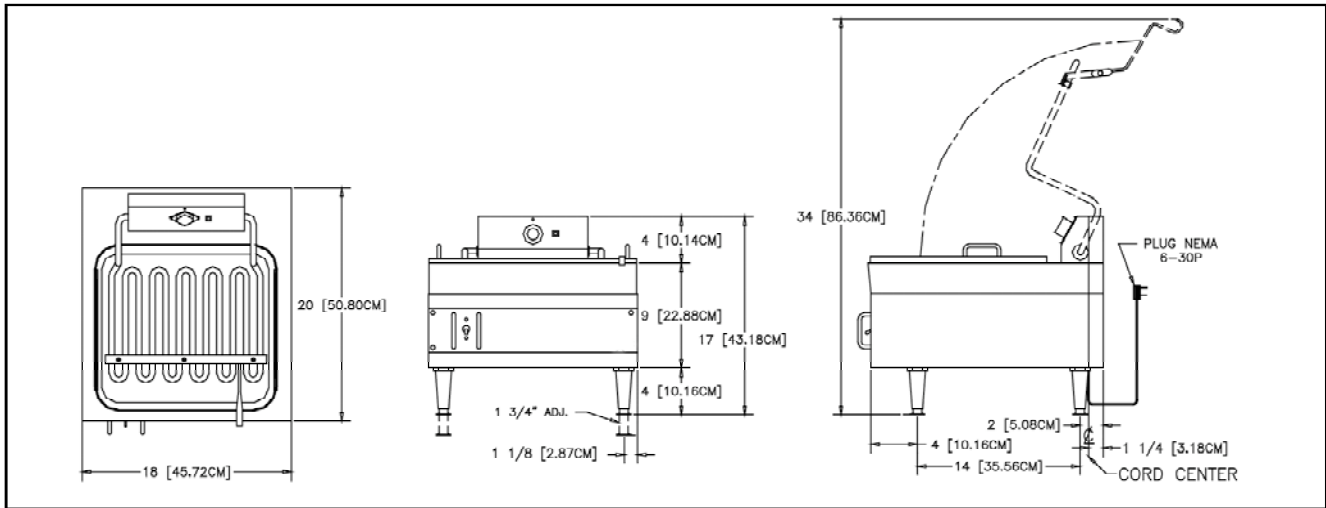

<b>Model Number</b>	<b>TMFE15</b>
<b>Overall Dimensions</b>	18" W x 17" H x 20" L
<b>Fat Container</b>	13" W x 3-3/4" H x 12" L
<b>Foam Compartment</b>	16" W x 3-3/8" H x 13" L
<b>Cooking Surface Height (In.) (cm)</b>	11 (27.9)
<b>Installed Weight (lbs.) (kg)</b>	37 lbs. (16.8)
<b>Shipping Weight (lbs.) (kg)</b>	47 lbs. (21.3)
<b>Pre-Heat time to 350°F (177°C)</b>	5 minutes
<b>Fat Capacity</b>	15 lbs. (6.8 kg)
<b>Pounds of French fries per hr.</b>	28 lbs. (12.7 kg)
<b>Watts per hr. to maintain 350°F</b>	430

4" (10cm) legs with 5-3/8" (13.7cm) adjustment

Model No.	Rated Wattage		Nominal Amps - Single Phase		NEMA Plug
	208V	240V	208V	240V	
TMFE15	4130	5500	19.9	22.9	6-30P

### Typical Specifications:

Electric fryers have a stainless steel body. A 200° - 375° (93°C - 190°C) adjustable thermostat and a hi-limit safety thermostat, and a separate on-off switch are standard. One and two piece nickel plated, lift out 15 lb. (6.8 kg) capacity steel kettle and 4" nickel-plated die-cast legs are standard. Unit has a tubular type, two position, swing-up element with a rated wattage of 5500 watts on 240 volts. Two side mounted nickel plated, perforated steel mesh baskets are provided as standard. A 6 ft. (182.9 cm) lead-in cord and plug with a NEMA 6-30P. UL listed to US and Canadian standard. UL Classified to NSF STD 4. Printed in the U.S.A.

**INTENDED FOR COMMERCIAL USE ONLY. NOT FOR HOUSEHOLD USE.**



Toastmaster, in line with its policy to continually improve its product, reserves the right to change materials or specifications without notice. Such revisions do not entitle the buyer to corresponding changes, improvements, additions, or replacements for previously purchased equipment.



**Toastmaster®** 10 Sunnen Dr, St. Louis MO 63143 • [www.toastmastercorp.com](http://www.toastmastercorp.com)  
Toll Free: 1-800-264-7827 • Telephone: 1-314-781-2777 • Fax: 1-314-781-3636