



Foodservice Equipment

Job _____ Item# _____

Electric Griddles TMGE24, TMGE36, TMGE48

Standard Features:

- Ultra smooth 3/4" thick polished steel plate.
- Available in 24", 36" and 48" widths.
- Snap action thermostat control from 150°- 450°F.
- A 4,000 watt element every 12" of cooking surface.
- Spatula wide 3-1/4" front grease trough and grease chute.
- Thermostat with positive "OFF" position.
- Stainless steel front panel, bull nose and grease drawer.
- 4-3/8" rear and side splash guards.
- 4" nickel plated steel legs.



TMGE48

Applications:

The Toastmaster Countertop Electric Griddle is the most economical and flexible Countertop Griddle in the food service industry. It offers unsurpassed performance, combining a proven control system with Toastmaster quality and durability. Available in three different sizes: 24", 36", and 48".

Warranty:

Toastmaster griddles are covered by Toastmaster's one year parts and labor warranty.

General Information:

Stainless steel front including top rail, with aluminized steel rear and sides. Full width stainless steel grease trough and easy to access grease drawer. 4-3/8" rear and side splash guards.



Electric Griddles

TMGE24, TMGE36, TMGE48

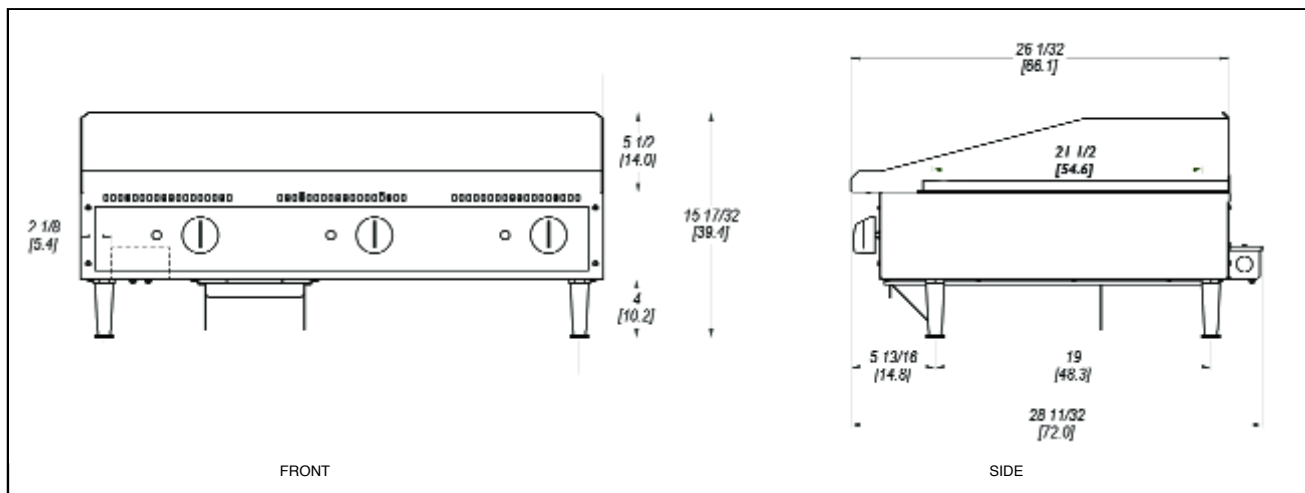

Model Number	TMGE24	TMGE36	TMGE48
Dimensions	24" W x 15-17/32" H x 27-13/16" L	36" W x 15-17/32" H x 27-13/16" L	48" W x 15-17/32" H x 27-13/16" L
Number of Controls	2	3	4
Griddle Plate Thickness	3/4"	3/4"	3/4"
Cook Zone Size	24"	36"	48"
Installed Weight (lbs.) (kg)	147 lbs. (67.0)	221 lbs. (100.5)	295 lbs. (134.1)
Shipping Weight (lbs.) (kg)	157 lbs. (71.4)	236 lbs. (107.3)	315 lbs. (143.2)

Model No.	Rated Wattage		3 Phase Loading KW Per Phase						Nominal Amps Per Line Wire							
	208V	240V	208V			240V			208V-3PH			240V-3PH			208V	240V
			X-Y	Y-Z	X-Z	X-Y	Y-Z	X-Z	X	Y	Z	X	Y	Z	1PH	1PH
TMGE24	6,008	8,000	3	3	-	4	4	-	14.4	25	14.4	16.7	28.9	16.7	28.9	33.3
TMGE36	9,012	12,000	3	3	3	4	4	4	25	25	25	28.9	28.9	28.9	-	-
TMGE48	12,016	16,000	3	3	6	4	4	8	38.2	25	38.2	44.2	28.9	44.2	57.8	66.7

Typical Specifications:

Electric griddles are constructed of stainless steel front panel and reinforced wall aluminized steel side panels. Griddle plate is 3/4" (1.9 cm) thick highly polished steel with 4-3/8" (11.1 cm) wrap-around stainless steel splash guard. Unit has a 3-1/4" (8.3cm) wide front grease trough with grease chute and 4-1/2 qt.(4.257 L) stainless steel grease drawer. Unit is heated with a 4000 watt incoloy sheath type element every 12" (30.48 cm) of griddle width and is controlled with a snap-action thermostat. Thermostat knob is protected by a stainless steel bull nose front. Units are supplied with 4" (10.16 cm) die cast nickel plated legs that have a 1-3/8" (3.5 cm) adjustment. A junction box is provided for making electrical connections. Units are listed by Underwriters Laboratories, and are UL Sanitation approved. Printed in the U.S.A.

INTENDED FOR COMMERCIAL USE ONLY. NOT FOR HOUSEHOLD USE.

TM107/1103



Toastmaster, in line with its policy to continually improve its product, reserves the right to change materials or specifications without notice. Such revisions do not entitle the buyer to corresponding changes, improvements, additions, or replacements for previously purchased equipment.



Toastmaster® 10 Sunnen Dr, St. Louis MO 63143 • www.toastmastercorp.com
Telephone: 1-314-678-6347 • Fax: 1-314-781-3636