



**TRUE FOOD SERVICE
EQUIPMENT, INC.**

St. Charles Industrial Center • P.O. Box 970 • O'Fallon, Missouri 63366
(636)240-2400 • FAX (636)272-2408 • (800)325-6152 • www.truemfg.com
Parts Dept. (800)424-TRUE • Parts Dept. FAX# (636)272-9471

Project Name: _____

Location: _____

Item #: _____ Qty: _____

Model #: _____

A/A #

SIS #

Model:
TPP-67

Pizza Prep Table:
Solid Door Refrigerator

TPP-67

- ▶ True's pizza prep tables are designed with enduring quality that protects your long term investment.
- ▶ Oversized, environmentally friendly (R134A) forced-air refrigeration system holds 33°F to 41°F (.5°C to 5°C).
- ▶ Complies with and listed under ANSI/NSF-7-1997-6.3.
- ▶ All stainless steel front, top and cabinet ends. Matching aluminum finished back.
- ▶ Stainless steel, patented, foam insulated flat lid(s) keeps pans temperatures colder and locks in freshness. Also minimizes condensation.
- ▶ Extra-deep 19 1/2" (496 mm) full length removable cutting board included. Sanitary, high-density, NSF approved polyethylene provides tough preparation surface.
- ▶ Foamed-in-place, high density polyurethane insulation (CFC free).
- ▶ Heavy duty PVC coated wire shelves.



ROUGH-IN DATA

Specifications subject to change without notice.
Chart dimensions rounded up to the nearest 1/8" (millimeters rounded up to next whole number).

Model	Solid Doors	Capacity (Cu. Ft.) (liters)	# of Shelves	Cabinet Dimensions (inches) (mm)			HP	Voltage	Amps	NEMA Config.	Cord Length (total ft.) (total m)	Crated Weight (lbs.) (kg)
				L**	D†	H*						
TPP-67	2	20.6 584	4	67 1/4	32 1/4	35 3/4	1/3	115/60/1	8.6	5-15P	7	400
				1709	820	909	1/3	230-240/50/1	4.2	▲	2.13	182

* Height does not include 6 1/4" (159 mm) for castors or 6" (153 mm) for optional legs.

▲ Plug type varies by country.

† Depth does not include 1" (26 mm) for rear bumpers and 3" (77 mm) for cutting board.

** Length does not include 1/4" (7 mm) each side for lid pins and 1/4" (7 mm) each side for cutting board brackets and thumb screws.



APPROVALS:

6/04

Printed in U.S.A.

Model:
TPP-67

Pizza Prep Table:
Solid Door Refrigerator



STANDARD FEATURES

DESIGN

- True's commitment to using the highest quality materials and oversized refrigeration systems provides the user with colder product temperatures, lower utility costs, superior food safety and the best value in today's food service marketplace.

REFRIGERATION SYSTEM

- Factory engineered, self-contained capillary tube system using environmentally friendly (CFC free) R134A refrigerant.
- Oversized, factory balanced refrigeration system with guided airflow to provide uniform temperature in food pan rail and cabinet interior.
- Forced-air design holds 33°F to 41°F (5°C to 5°C) product temperature in food pans and cabinet interior. Complies with and listed under ANSI/ NSF-7-1997-6.3.
- Condensing unit accessed from front behind removable panel on right hand side of cabinet, slides out for easy maintenance.

CABINET CONSTRUCTION

- Exterior - stainless steel front, top and cabinet ends. Matching aluminum finished back.
- Interior - attractive, NSF approved, white aluminum liner. 300 series stainless floor with coved corners.

- Insulation - entire cabinet structure and solid doors are foamed-in-place using high density, CFC free, polyurethane insulation.
- 5" (127 mm) diameter stem castors. 36" (915 mm) work surface height.

DOORS

- Stainless steel exterior with white aluminum liner to match cabinet interior.
- Doors swing within cabinet dimensions.
- Doors fitted with 12" (305 mm) long recessed handle that is foamed-in-place with a sheet metal interlock to insure permanent attachment.
- Magnetic door gaskets of one piece construction, removable without tools for ease of cleaning.

SHELVING

- Four (4) adjustable, heavy duty PVC coated wire shelves 23 5/8" L x 28" D (601 mm x 712 mm). Four (4) chrome plated shelf clips included per shelf.
- Shelf support pilasters made of same material as cabinet interior; shelves are adjustable on 1/2" (13 mm) increments.

MODEL FEATURES

- Evaporator is epoxy coated at time of manufacture to eliminate the potential of corrosion.
- Extra-deep 19 1/2" D (496 mm) full length removable cutting board included. Sanitary, high-density, NSF

approved polyethylene provides tough preparation surface.

- Stainless steel, patented, foam insulated flat lids keep pan temperatures colder and locks in freshness. Also minimizes condensation.
- Refrigerated pan rail comes standard with nine (1/3 size) 12" L x 6" D x 6" H (305 mm x 153 mm x 153 mm) NSF approved clear polycarbonate insert pans.

ELECTRICAL

- Unit completely pre-wired at factory and ready for final connection to a 115/60/1 phase - 15 amp dedicated outlet. Cord and plug set included.



115/60/1
NEMA-5-15R

OPTIONAL FEATURES/ACCESSORIES

- 230 - 240V / 50 Hz.
- 6" (153 mm) standard or seismic/ flanged legs.
- Garnish racks.
- Service shelf.
- Half bun tray racks. Holds up to eleven 18" L x 26" D (158 mm x 661 mm) sheet pans (sold separately).
- Remote cabinets (condensing unit supplied by others), consult factory technical service department for BTU information.

PLAN VIEW

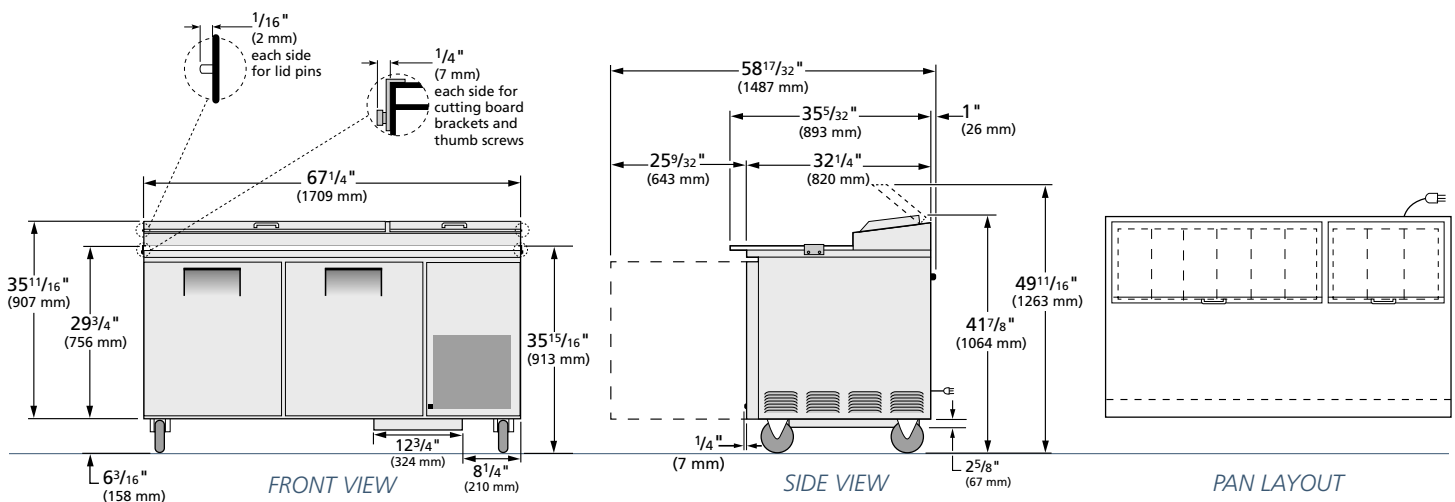

WARRANTY
 One year warranty on all parts & labor and an additional 4 year warranty on compressor. (U.S.A. only)

METRIC DIMENSIONS ROUNDED UP TO THE NEAREST WHOLE MILLIMETER
 SPECIFICATIONS SUBJECT TO CHANGE WITHOUT NOTICE



Model	Front	Side	Plan	3D
TPP-67	TFQY11E	TFQY10S	TFQY11P	TFQY113

TRUE FOOD SERVICE EQUIPMENT