



**TRUE FOOD SERVICE  
EQUIPMENT, INC.**

St. Charles Industrial Center • P.O. Box 970 • O'Fallon, Missouri 63366  
(636)240-2400 • FAX (636)272-2408 • (800)325-6152 • www.truemfg.com  
Parts Dept. (800)424-TRUE • Parts Dept. FAX# (636)272-9471

Project Name: \_\_\_\_\_

Location: \_\_\_\_\_

Item #: \_\_\_\_\_ Qty: \_\_\_\_\_

Model #: \_\_\_\_\_

A/A #

SIS #

Model:  
**TPP-67D-4**

**Pizza Prep Table:**  
*Drawered Refrigerator*



### TPP-67D-4

- ▶ True's pizza prep tables are designed with enduring quality that protects your long term investment.
- ▶ Oversized, environmentally friendly (R134A) forced-air refrigeration system holds 33°F to 41°F (.5°C to 5°C).
- ▶ Complies with and listed under ANSI/NSF-7-1997-6.3.
- ▶ All stainless steel front, top and cabinet ends. Matching aluminum finished back.
- ▶ Stainless steel, patented, foam insulated flat lids keeps pans temperatures colder and locks in freshness. Also minimizes condensation.
- ▶ Extra-deep 19 1/2" (496 mm) full length removable cutting board included. Sanitary, high-density, NSF approved polyethylene provides tough preparation surface.
- ▶ Foamed-in-place, high density polyurethane insulation (CFC free).
- ▶ Each drawer accommodates (2) 12" L x 20" W x 8" D (305 mm x 508 mm x 204 mm) pans (sold separately).

### ROUGH-IN DATA

Specifications subject to change without notice.  
Chart dimensions rounded up to the nearest 1/8" (millimeters rounded up to next whole number).

Model	Drawers	Capacity (Cu. Ft.) (liters)	Cabinet Dimensions (inches) (mm)			HP	Voltage	Amps	NEMA Config.	Cord Length (total ft.) (total m)	Crated Weight (lbs.) (kg)
			L**	D†	H*						
TPP-67D-4	4	20.6 524	67 1/4	32 1/4	35 3/4	1/3	115/60/1	8.6	5-15P	7 2.13	490 223
			1709	820	909	1/3	230-240/50/1	4.2			

\* Height does not include 6 1/4" (159 mm) for castors or 6" (153 mm) for optional legs.

▲ Plug type varies by country.

† Depth does not include 1" (26 mm) for rear bumpers and 3" (77 mm) for cutting board.

\*\* Length does not include 1/4" (7 mm) each side for lid pins and 1/4" (7 mm) each side for cutting board brackets and thumb screws.



APPROVALS:

6/04

Printed in U.S.A.

Model:  
**TPP-67D-4**

**Pizza Prep Table:**  
Drawered Refrigerator



**STANDARD FEATURES**

**DESIGN**

- True's commitment to using the highest quality materials and oversized refrigeration systems provides the user with colder product temperatures, lower utility costs, superior food safety and the best value in today's food service marketplace.

**REFRIGERATION SYSTEM**

- Factory engineered, self-contained capillary tube system using environmentally friendly (CFC free) R134A refrigerant.
- Oversized, factory balanced refrigeration system with guided airflow to provide uniform temperature in food pan rail and cabinet interior.
- Forced-air design holds 33°F to 41°F (.5°C to 5°C) product temperature in food pans and cabinet interior. Complies with and listed under ANSI/ NSF-7-1997-6.3.
- Condensing unit accessed from front behind removable panel on right hand side of cabinet, slides out for easy maintenance.

**CABINET CONSTRUCTION**

- Exterior - stainless steel front, top and cabinet ends. Matching aluminum finished back.
- Interior - attractive, NSF approved, white aluminum liner. 300 series stainless floor with coved corners.

- Insulation - entire cabinet structure and solid doors are foamed-in-place using high density, CFC free, polyurethane insulation.
- 5" (127 mm) diameter stem castors. 36" (915 mm) work surface height.

**DRAWERS**

- Stainless steel exterior with white aluminum liner to match cabinet interior.
- Heavy duty all stainless steel sides.
- Each drawer fitted with 12" (305 mm) long recessed handle that is foamed-in-place with a sheet metal interlock to insure permanent attachment.
- Magnetic door gaskets of one piece construction, removable without tools for ease of cleaning.

**SHELVING**

- Each drawer accommodates (2) 12"L x 20"W x 8"D (305 mm x 508 mm x 204 mm) food pans (sold separately). Drawers will support varying pan configurations with pan dividers bars (drawer pans and divider bars optional).
- Heavy-duty stainless steel drawer slides and rollers. Removable without tools for easy cleaning.

**MODEL FEATURES**

- Evaporator is epoxy coated at time of manufacture to eliminate the potential of corrosion.
- Extra-deep 19 1/2"D (496 mm) full length removable cutting board

included. Sanitary, high-density, NSF approved polyethylene provides tough preparation surface.

- Stainless steel, patented, foam insulated flat lids keep pan temperatures colder and locks in freshness. Also minimizes condensation.
- Refrigerated pan rail comes standard with nine (1/3 size) 12"L x 6"W x 6"D (305 mm x 153 mm x 153 mm) NSF approved clear polycarbonate insert pans.

**ELECTRICAL**

- Unit completely pre-wired at factory and ready for final connection to a 115/60/1 phase - 15 amp dedicated outlet. Cord and plug set included.



115/60/1  
NEMA-5-15R

**OPTIONAL FEATURES/ACCESSORIES**

- 230 - 240V / 50 Hz.
- 6" (153 mm) standard or seismic/ flanged legs.
- Garnish racks.
- Service shelf.
- Remote cabinets (condensing unit supplied by others), consult factory technical service department for BTU information.

**PLAN VIEW**

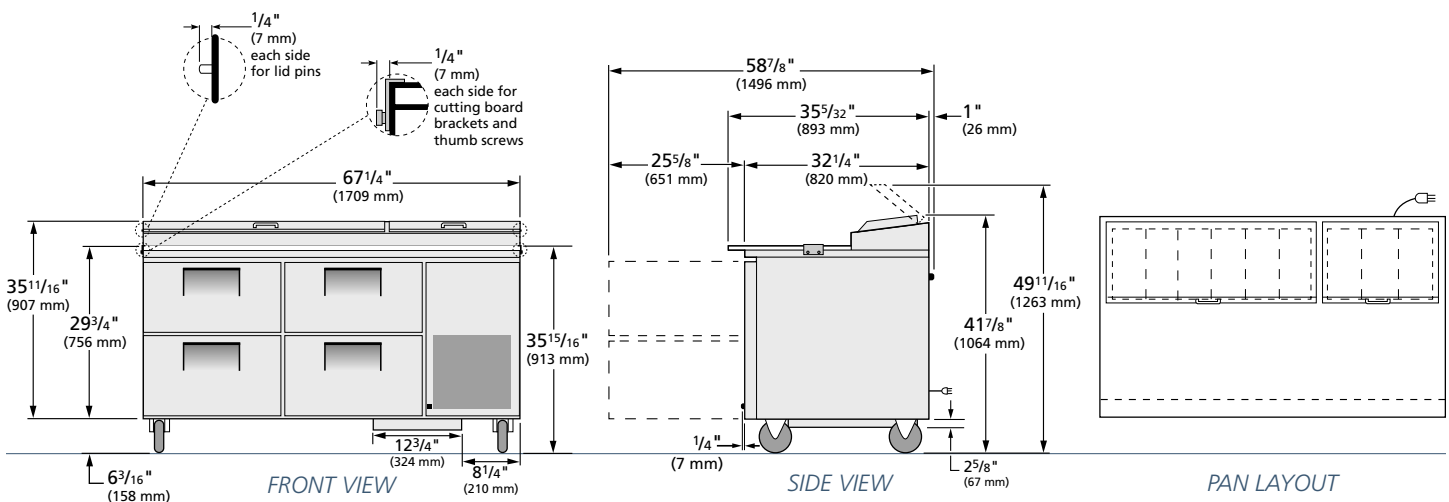

**WARRANTY**  
 One year warranty on all parts & labor and an additional 4 year warranty on compressor. (U.S.A. only)

METRIC DIMENSIONS ROUNDED UP TO THE NEAREST WHOLE MILLIMETER  
 SPECIFICATIONS SUBJECT TO CHANGE WITHOUT NOTICE



Model	Front	Side	Plan	3D
TPP-67D-4	TFQ042E	TFQY41S	TFQY42P	TFQY423

**TRUE FOOD SERVICE EQUIPMENT**