

REFRIGERATOR MANUFACTURER
Turbo air
 more durable, efficient, beautiful

4184 E. Conant st.
 Long Beach, CA 90808
 Tel. 310-900-1000
 Fax. 310-900-1077
www.turboairinc.com

Project :	
Model # :	
Item # :	Qty :
Available W/H :	
Approval :	

Two Compartment Sinks (Two Drain Boards)

HIGH QUALITY 304 STAINLESS STEEL

**Model : TSA-2-12-D1 / TSA-2-14-D2
 TSA-2-D1 / TSB-2-D2 / TSC-2-D2**



* Faucet sold separately

- ENTIRE ASSEMBLY IS FUSED, SHIELDED AND POLISHED PROVIDING A ONE-PIECE SEAMLESS SINK UNIT
- WELDED AREAS ARE HIGH-SPEED BELT BLENDED TO MATCH ADJACENT SURFACES WITH THE CONTINUITY OF A SATIN FINISH
- ALL SINK COMPARTMENTS ARE COVERED ON A FULL 5/8" RADIUS AND CONSTRUCTED USING STATE OF THE ART SEAMLESS WELDING TECHNIQUES
- DIE-STAMPED CREASED DRAIN BOARDS FOR POSITIVE DRAINAGE
- SWIRL AWAY BOWL DRAINAGE
- GALVANIZED LEGS AND GUSSETS
- ADJUSTABLE ABS BULLET FEET
- STAINLESS STEEL LEGS AVAILABLE (OPTIONAL)

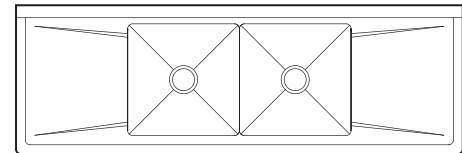
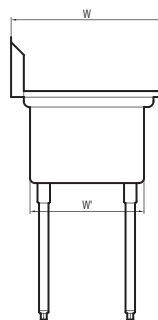
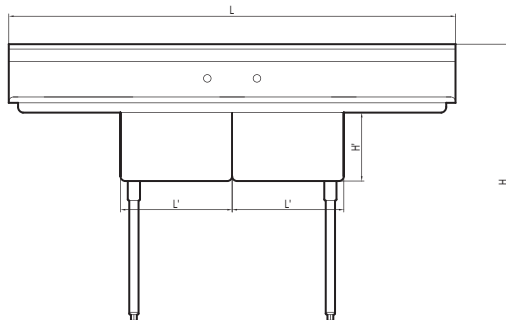

(unit : inch)

Model	Ga.	Bowl Size (L' x W' x H')	Length	Width	Height	# of Faucet Accepted	Net Weight* (lbs.)
TSA-2-12-D1	18	18x18x12	72	24	44 1/2	1	66
TSA-2-14-D2	18	18x18x14	84	24	44 1/2	1	73
TSA-2-D1	18	18x18x11	72	24	44 1/2	1	63
TSB-2-D2	16	24x24x14	96	30	44 1/2	1	123
TSC-2-D2	18	18x18x14	84	27	44 1/2	1	111

Ver.201410

Information and specifications are subject to change without notice.

* All net weights are approximated. Crafting fee will be added for shipping via common carriers (Please confirm at the time of the purchase).