

**REFRIGERATOR MANUFACTURER**  
**Turbo air**  
 more durable, efficient, beautiful

4184 E. Conant st.  
 Long Beach, CA 90808  
 Tel. 310-900-1000  
 Fax. 310-900-1077  
[www.turboairinc.com](http://www.turboairinc.com)

Project :	
Model # :	
Item # :	Qty :
Available W/H :	
Approval :	

## One Compartment Sinks (Two Drain Boards)

**HIGH QUALITY 304 STAINLESS STEEL**

**Model : TSA-1-D1  
 TSB-1-D2**



**TSA-1-D1**

\* Faucet sold separately

- ENTIRE ASSEMBLY IS FUSED, SHIELDED AND POLISHED PROVIDING A ONE-PIECE SEAMLESS SINK UNIT
- WELDED AREAS ARE HIGH-SPEED BELT BLENDED TO MATCH ADJACENT SURFACES WITH THE CONTINUITY OF A SATIN FINISH
- ALL SINK COMPARTMENTS ARE COVERED ON A FULL 5/8" RADIUS AND CONSTRUCTED USING STATE OF THE ART SEAMLESS WELDING TECHNIQUES
- DIE-STAMPED CREASED DRAIN BOARDS FOR POSITIVE DRAINAGE
- SWIRL AWAY BOWL DRAINAGE
- GALVANIZED LEGS AND GUSSETS
- ADJUSTABLE ABS BULLET FEET
- STAINLESS STEEL LEGS AVAILABLE (OPTIONAL)

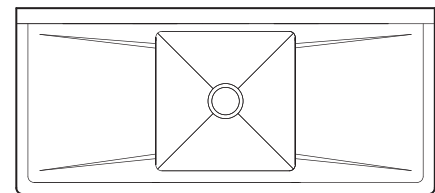
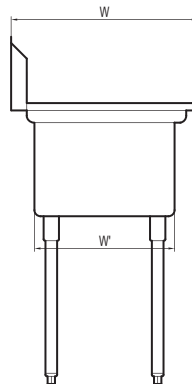
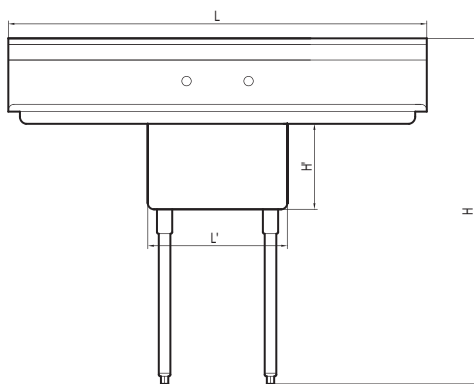

(unit : inch)

Model	Ga.	Bowl Size (L' x W' x H')	Length	Width	Height	# of Faucet Accepted	Net Weight* (lbs.)
TSA-1-D1	18	18x18x11	54	24	44 1/2	1	45
TSB-1-D2	16	24x24x14	72	30	44 1/2	1	84

Ver.201410

Information and specifications are subject to change without notice.  
 \* All net weights are approximated. Crafting fee will be added for shipping via common carriers (Please confirm at the time of the purchase).