

**REFRIGERATOR MANUFACTURER**  
**Turbo air**  
 more durable, efficient, beautiful

4184 E. Conant St.  
 Long Beach, CA 90808  
 Tel. 310-900-1000  
 Fax. 310-900-1077  
[www.turboairinc.com](http://www.turboairinc.com)

Project :	
Model # :	
Item # :	Qty :
Available W/H :	
Approval :	

## Glass / Mug Frosters

*Underbar Equipment  
 Super Deluxe Series*

### Patented Self-Cleaning Condenser

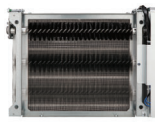

This product is equipped with a fine mesh filter to the front of the condenser to catch dust, and a rotating brush that moves up and down daily to remove excess buildup outward and away.

### Model : TBC-50SD/SB-GF-N



**TBC-50SD-GF-N**



**TBC-50SB-GF-N**

### ≡ FEATURES & BENEFITS ≡

- Self-Cleaning Condenser**  
 The accumulation of dust in the condenser can cause the failure or breakdown of refrigerators. Refrigerators run normally until they reach a certain level of accumulation. At some point, when they are over the limit, their performance drops quickly resulting in damage to, or disposal of the stored products inside. The Self-Cleaning Condenser device keeps the condenser clean and prevents system failure by automatically brushing daily.
- Hydrocarbon refrigerants (R-290)**  
 With innovative and eco-friendly technology, Turbo Air brings you hydrocarbon refrigerators designed to meet DOE's Energy Conservation Standards in 2017 and to use EPA's SNAP Program approved HC refrigerants. Hydrocarbon refrigerants do not deplete the ozone layer and have very low contribution to global warming (ODP-0, GWP-3).
- Stainless steel cabinet construction**  
 Super Deluxe (SD) models boast a stainless steel exterior (except galvanized steel back and bottom). SB models have an attractive wear-resistant black vinyl exterior. Heavy gauge stainless steel countertop and glide lids are perfect for sanitation and durability. The interior is stainless steel except galvanized steel top. Turbo Air Glass Froster model guarantees the utmost in cleanliness and long product life. It also adds a touch of style to the most refined setting.
- Manual defrost system**
- High-density polyurethane insulation**  
 The entire cabinet structure is foamed-in-place using high density, HCFC free polyurethane insulation.
- Heavy duty, PE (polyethylene) coated dividers**  
 Heavy duty 10mm thick pure grade PE coated shelves are provided for maximum storage use.
- Direct cooling type**
- Large capacity cooler cabinet requires only minimum floor space**
- Side mount compressor unit**  
 With compressors positioned on the side of the unit, our refrigerators can now be serviced without being moved. Our innovative, front breathing feature also allows this model to be highly efficient in narrow spaces.
- Glass/mug froster holds -5°F ~ 15°F for the best in chilling glasses and plates**



Model	Sliding Door	CU./FT.	Capacity 8" Mug / 10oz Stein	# of Shelves	HP	AMPS	Crated Weight (lbs.)	L x D' x H† (inches)
TBC-50SD-GF-N	2	14.49	140 / 386 Cups	5	1/3	1.7	280	50 x 26 1/2 x 33 1/4
TBC-50SB-GF-N	2	14.49	140 / 386 Cups	5	1/3	1.7	280	50 x 26 1/2 x 33 1/4

## Model : TBC-50SD/SB-GF-N

ELECTRICAL DATA	
Voltage	115/60/1
Plug Type	Ⓜ NEMA 5-15P
Full Load Amperes	1.7
Compressor HP	1/3
Refrigerant	R-290
Cord Length (ft.)	8.5
DIMENSIONAL DATA	
Capacity (8" Mug / 10oz Stein)	140 Cups / 386 Cups
Net Capacity (cu. ft.)	14.49
Ext. Length Overall (in.)	50 (1270mm)
Ext. Depth Overall (in.)*	26 1/2 (673mm)
Ext. Height Overall (in.)†	33 1/4 (845mm)
Net Weight (lbs.)	240
Gross Weight (lbs.)	280
# of Shelves	5
# of Casters	5EA 

Design and specifications subject to change without notice.

Actual shipping weight may differ due to extra packing materials for product protection.

\* Depth does not include 2" for rear spacers.

† Height does not include 5" for caster height.

■ **WARRANTY : 3 Year Parts and Labor Warranty**  
Additional 2 Year Warranty on Compressor

### ■ STANDARD FEATURES

- *Anti-corrosion coated evaporator*
- *Self-contained system*
- *Standard 4" dia. swivel casters with locks on the front set*

### ■ OPTIONAL ACCESSORIES

- 2" caster for underbar series, 1/2" diameter: P0165B0100 (non-brake), P0165B0110 (w/ brake)
- 2.5" caster: 30265H0100 (non-brake), 30265H0200 (w/ brake)
- 5" caster, 1/2" diameter & 13 TPI: M726500100 (non-brake), M726500200 (w/ brake)
- 6" adjustable stainless steel leg: P0121P0100

## PLAN VIEW

(unit : inch)

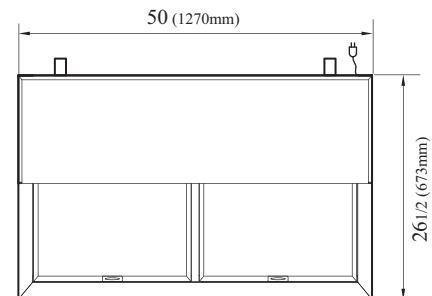

PLAN VIEW

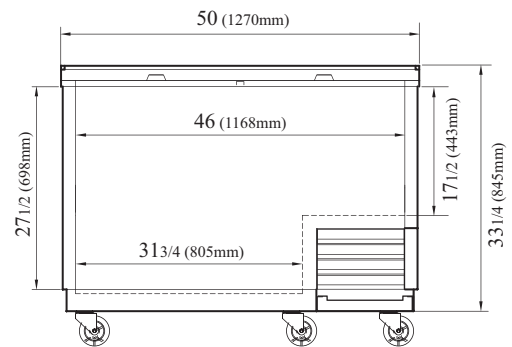

FRONT VIEW

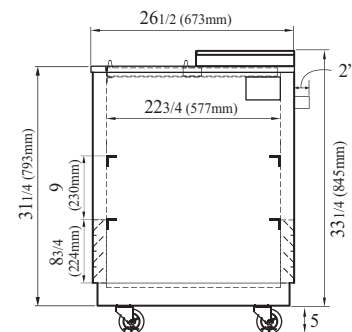

SIDE VIEW

Ver.20190510



■ Turbo Air : 800-627-0032 ■ GK : 800-500-3519  
■ Warranty : 800-381-7770 ■ AC : 888-900-1002