

REFRIGERATOR MANUFACTURER
Turbo air
 more durable, efficient, beautiful

4184 E. Conant St.
 Long Beach, CA 90808
 Tel. 310-900-1000
 Fax. 310-900-1077
www.turboairinc.com

Project :	
Model # :	
Item # :	Qty :
Available W/H :	
Approval :	

Swing Door Merchandisers

Glass Door Merchandisers
 Super Deluxe Series

Model : TGM-20SD-N6

≡ FEATURES & BENEFITS ≡

■ Self-Cleaning Condenser

The accumulation of dust in the condenser can cause the failure or breakdown of refrigerators. Refrigerators run normally until they reach a certain level of accumulation. At some point, when they are over the limit, their performance drops quickly resulting in damage to, or disposal of the stored products inside. The Self-Cleaning Condenser device keeps the condenser clean and prevents system failure by automatically brushing daily.

■ Digital temperature control & monitor system

- Keep food products safe by maintaining constant temperatures.
- Alarms that sound when doors are not sealed shut; protect against food spoilage that originates from cold air leaks.
- Early Warning Alarm program detects issues before malfunction occurs.
- Digital display allows for easy monitoring.
- Programs interpret the condition of refrigeration systems by self-diagnosis.
- Rapid cool-down function (Turbo cooling).
- Automatic evaporator fan motor delays.

■ Hydrocarbon refrigerants (R-600a)

With innovative and eco-friendly technology, Turbo Air brings you hydrocarbon refrigerators designed to meet DOE's Energy Conservation Standards in 2017 and to use EPA's SNAP Program approved HC refrigerants. Hydrocarbon refrigerants do not deplete the ozone layer and have very low contribution to global warming (ODP-0, GWP-3).

■ Energy conserving fan control

Utilizing algorithmic air circulation for optimal temperature levels, our innovative fan control system conserves energy by at least 15% and increases compressor life by up to 30%.

■ Double pane glass doors with Low-E glass

Energy saving double pane glass doors are equipped with Low-emissivity glass, which reduces outer heat gain and decreases energy consumption. It enhances energy efficiency and minimizes condensation. Lightweight door construction also reduces door maintenance and bushing wear, which in turn facilitates smoother door opening.

■ High-density polyurethane insulation

The entire cabinet structure is foamed-in-place using high density, HCFC free polyurethane insulation.

■ Shadow free advertising panel

Turbo Air is a pioneer in the refrigerator industry on applying special LED Light Guided Panels (LGP). LGP increases panel visibility and eliminates shadows, enhancing any store atmosphere with eye-catching effects. LED lighting offers 5 times longer lasting life than fluorescents and conserves energy as well.

■ LED interior lighting

■ Refrigerator holds 33°F ~ 38°F for the best in food preservation



TGM-20SDW-N6



TGM-20SDB-N6

Patented Self-Cleaning Condenser

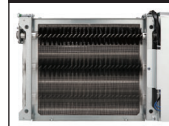

This product is equipped with a fine mesh filter to the front of the condenser to catch dust, and a rotating brush that moves up and down daily to remove excess buildup outward and away.



Model	Swing Door	CU./FT.	#of Shelves	HP	AMPS	Crated Weight (lbs.)	L x D* x H† (inches)
TGM-20SD-N6	1	16.01	4	1/5	2.4	292	27 x 263/8 x 77

Model : TGM-20SD-N6

ELECTRICAL DATA	
Voltage	115/60/1
Plug Type	 NEMA 5-15P
Full Load Amperes	2.4
Compressor HP	1/5
Cord Length (ft.)	7
Refrigerant	R-600a
DIMENSIONAL DATA	
# of Doors	1
Net Capacity (cu. ft.)	16.01
Ext. Length Overall (in.)	27 (685mm)
Ext. Depth Overall (in.)*	26 ³ / ₈ (670mm)
Ext. Height Overall (in.)†	77 (1955mm)
Int. Length Overall (in.)	23 (585mm)
Int. Depth Overall (in.)	21 ⁷ / ₈ (555mm)
Int. Height Overall (in.)	60 ¹ / ₄ (1530mm)
Net Weight (lbs.)	269
Gross Weight (lbs.)	292
# of Shelves	4
Shelf Size (L x D) (in.)	21 ¹ / ₂ x 17 ¹ / ₂

Design and specifications subject to change without notice.
Actual shipping weight may differ due to extra packing materials for product protection.
* Depth does not include 2-1/4" (57mm) for door handle.
† Height does not include 2-1/2" (63mm) for leg height.

■ **WARRANTY : 3 Year Parts and Labor Warranty**
Additional 2 Year Warranty on Compressor

■ **Standard features**

- Anti-corrosion coated evaporator
- Door locks standard

* **Two color options available (standard):** white cabinet (W), black cabinet with black color trim (B).

* Please allow extra lead time for white cabinet with wine color trim.

■ **OPTIONAL ACCESSORIES :**

- 4" caster, 1/2" diameter & 13 TPI: G8F6500101 (non-brake), G8F6500201 (w/ brake)
- Additional PE coated wire shelf: P0178H0100
- Price tag channel available

PLAN VIEW

(unit : inch)

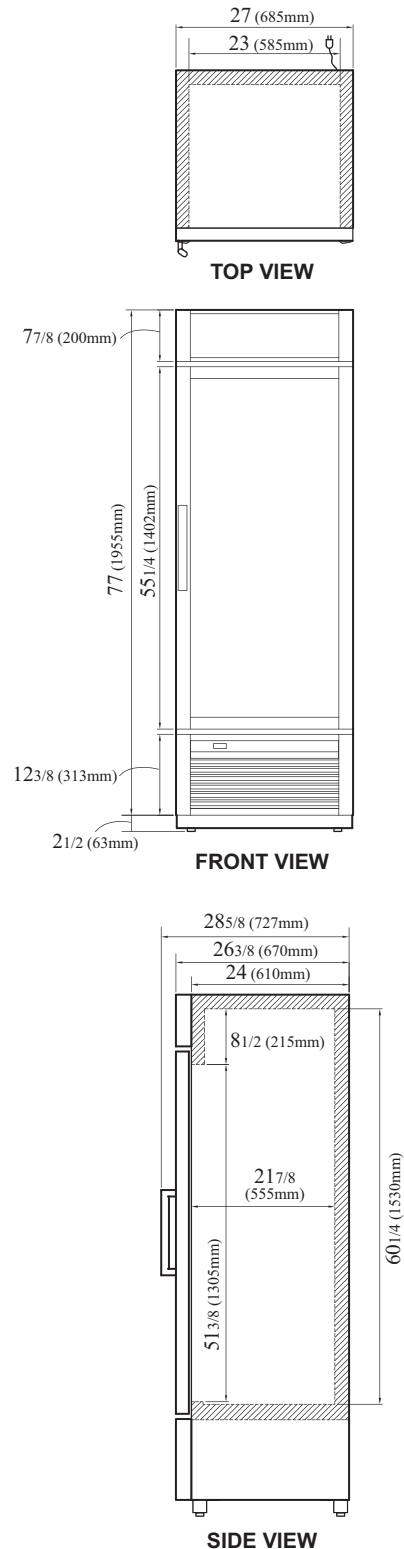

Ver.20190408



- Turbo Air : 800-627-0032
- GK : 800-500-3519
- Warranty : 800-381-7770
- AC : 888-900-1002