

REFRIGERATOR MANUFACTURER
Turbo air
 more durable, efficient, beautiful

4184 E. Conant St.
 Long Beach, CA 90808
 Tel. 310-900-1000
 Fax. 310-900-1077
www.turboairinc.com

| | |
|-----------------|-------|
| Project : | |
| Model # : | |
| Item # : | Qty : |
| Available W/H : | |
| Approval : | |

Worktop Freezer - Drawers

Worktops
 Super Deluxe Series

Patented Self-Cleaning Condenser



This product is equipped with a fine mesh filter to the front of the condenser to catch dust, and a rotating brush that moves up and down daily to remove excess buildup outward and away.

Model : TWF-48SD-D2-N



- Each drawer accommodates up to 6" deep sixth (1/6) size pans (drawer pans not included)

≡ FEATURES & BENEFITS ≡

■ Self-Cleaning Condenser

The accumulation of dust in the condenser can cause the failure or breakdown of refrigerators. Refrigerators run normally until they reach a certain level of accumulation. At some point, when they are over the limit, their performance drops quickly resulting in damage to, or disposal of the stored products inside. The Self-Cleaning Condenser device keeps the condenser clean and prevents system failure by automatically brushing daily.

■ Digital temperature control & monitor system

Keep food products safe by maintaining constant temperatures. External digital display allows for easy monitoring.

■ Hydrocarbon refrigerants (R-290)

With innovative and eco-friendly technology, Turbo Air brings you hydrocarbon refrigerators designed to meet DOE's Energy Conservation Standards in 2017 and to use EPA's SNAP Program approved HC refrigerants. Hydrocarbon refrigerants do not deplete the ozone layer and have very low contribution to global warming (ODP-0, GWP-3).

■ Stainless steel cabinet construction

The Turbo Air Super Deluxe model boasts a stainless steel interior and exterior (galvanized steel back & bottom). It guarantees the utmost in cleanliness and long product life. The Super Deluxe adds a touch of style to the most refined setting.

■ Sturdy, clean stainless steel shelving

Shelves are the most important part of cleanliness as they come in direct contact with food. After a while, PVC coated wire shelves may peel, rust and lead to unsanitary conditions. Only the Turbo Air Super Deluxe series uniquely provides stainless steel shelving.

■ Ergonomically designed doors

Customers' fatigue fades away with easy grip handles and doors that open effortlessly. These features along with self-closing doors make this the ultimate choice in customer convenience. ABS sheet door liners resist water condensation with thermal efficiency.

■ High-density polyurethane insulation

The entire cabinet structure and solid doors are foamed-in-place using high density, CFC free polyurethane insulation.

■ Magnetic door gaskets

Magnetic door gaskets are of one-piece construction, removable without tools for ease of cleaning and replacement.

■ Freezer holds -10°F ~ 0°F for the best in frozen food preservation

NATURAL Refrigerant

ISO9001:2008

Intertek

Intertek

5 YEAR WARRANTY

Compressor 5 YEAR WARRANTY U.S.A. only

| Model | Swing Door | Drawers | CU./FT. | #of Shelves | HP | AMPS | Crated Weight (lbs.) | L x D x H [†] (inches) |
|---------------|------------|---------|---------|-------------|-----|------|----------------------|---------------------------------|
| TWF-48SD-D2-N | 1 | 2 | 12 | 1 | 1/3 | 2.8 | 264 | 48 1/4 x 30 x 33 1/2 |

Model : TWF-48SD-D2-N

| ELECTRICAL DATA | |
|----------------------------|-----------------|
| Voltage | 115/60/1 |
| Plug Type | ⓘ NEMA 5-15P |
| Full Load Amperes | 2.8 |
| Compressor HP | 1/3 |
| Cord Length (ft.) | 9 |
| Refrigerant | R-290 |
| DIMENSIONAL DATA | |
| Net Capacity (cu. ft.) | 12 |
| Ext. Length Overall (in.) | 48 1/4 (1226mm) |
| Ext. Depth Overall (in.)* | 30 (762mm) |
| Ext. Height Overall (in.)† | 33 1/2 (851mm) |
| # of Doors | 1 |
| # of Shelves | 1 |
| Net Weight (lbs.) | 242 |
| Gross Weight (lbs.) | 264 |
| Shelf Size (in.) | 21 x 17 |

Design and specifications subject to change without notice.

Actual shipping weight may differ due to extra packing materials for product protection.

* Depth does not include 1" for rear spacers.

† Height does not include 5" for caster height.

■ **WARRANTY : 3 Year Parts and Labor Warranty**
Additional 2 Year Warranty on Compressor

■ **STANDARD FEATURES**

- Anti-corrosion coated evaporator
- Self-contained system
- Standard 4" dia. swivel casters with locks on the front set

■ **OPTIONAL ACCESSORIES :**

- 2.5" caster, 1/2" diameter & 13 TPI: 30265H0100 (non-brake), 30265H0200 (w/ brake)
- 5" caster, 1/2" diameter & 13 TPI: M726500100 (non-brake), M726500200 (w/ brake)
- 6" ABS plastic leg: 30221M0200
- 6" stainless steel leg: 30221M0600
- Additional stainless steel shelf: M727800100

PLAN VIEW

(unit : inch)

* Each drawer accommodates up to 6" deep sixth (1/6) size pans (drawer pans not included)

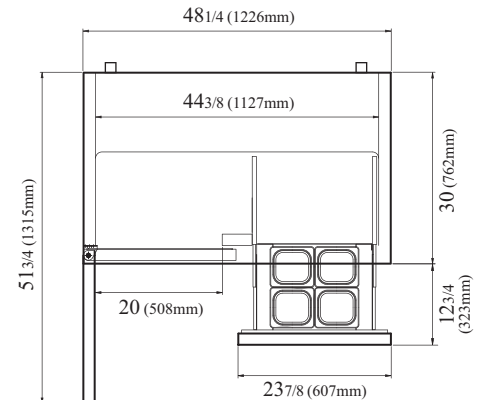

PLAN VIEW

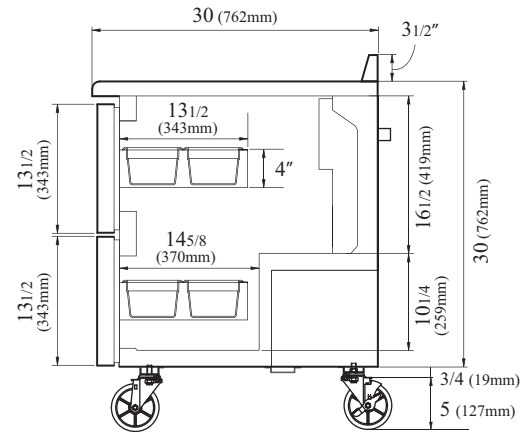

SIDE VIEW

Ver.20190206



- Turbo Air : 800-627-0032
- GK : 800-500-3519
- Warranty : 800-381-7770
- AC : 888-900-1002