

REFRIGERATOR MANUFACTURER
Turbo air
 more durable, efficient, beautiful

4184 E. Conant St.
 Long Beach, CA 90808
 Tel. 310-900-1000
 Fax. 310-900-1077
www.turboairinc.com

Project:	
Model #:	
Item #:	
Available W/H:	Qty:
Approval:	
AIA #:	SIS #:
CSI Section 11400	

Undercounter Refrigerator - Drawers / Front Breathing Airflow

Undercounters
 PRO Series

Patented Self-Cleaning Condenser



This product is equipped with a fine mesh filter to the front of the condenser to catch dust, and a rotating brush that moves up and down daily to remove excess buildup outward and away.

Model : PUR-48-D2R-FB-N
PUR-48-D2L-FB-N



PUR-48-D2L-FB-N



PUR-48-D2R-FB-N

≡ FEATURES & BENEFITS ≡

- Self-Cleaning Condenser**
 The accumulation of dust in the condenser can cause the failure or breakdown of refrigerators. Refrigerators run normally until they reach a certain level of accumulation. At some point, when they are over the limit, their performance drops quickly resulting in damage to, or disposal of the stored products inside. The Self-Cleaning Condenser device keeps the condenser clean and prevents system failure by automatically brushing daily.
- Digital temperature control & monitor system**
 Keeps food products safe by maintaining constant temperatures. External digital display allows for easy monitoring.
- Front Breathing airflow**
 Front Breathing airflow is designed to draw in air and discharge from the front, allowing units to run at high efficiency in tight spaces and eliminates the need for surrounding clearances.
- Hydrocarbon refrigerants (R-290)**
 With innovative and eco-friendly technology, Turbo Air brings you hydrocarbon refrigerators designed to meet DOE's Energy Conservation Standards in 2017 and to use EPA's SNAP Program approved HC refrigerants. Hydrocarbon refrigerants do not deplete the ozone layer and have very low contribution to global warming (ODP-0, GWP-3).
- Stainless steel cabinet construction**
 The PRO series model boasts a stainless steel interior (Aluminum door liner) and a **22 gauge** stainless steel exterior (galvanized steel bottom). It guarantees the utmost in cleanliness and long product life. The PRO series adds a touch of style to the most refined setting.
- Lifetime guaranteed heavy duty handles**
- High-density polyurethane insulation**
 The entire cabinet structure and solid doors are foamed-in-place using high density, CFC free polyurethane insulation.
- Each top drawer accommodates up to 6" deep, one (1) full size pan or two (2) 1/3 size pans with two (2) 1/6 size pans or six (6) 1/6 size pans. And each bottom drawer accommodates up to 6" deep, two (2) 1/3 size pans or four (4) 1/6 size pans (drawer pans not included)**
- Refrigerator holds 33°F ~ 38°F for the best in food preservation**
- Built to maintain NSF standard temperatures in 100°F ambient**

- PUR-48-D2R-FB-N: (Left) Drawers + (Right) Right hinged door
- PUR-48-D2L-FB-N: (Right) Drawers + (Left) Left hinged door

NATURAL Refrigerant



Model	Swing Doors	Drawers	CU./FT.	#of Shelves	HP	AMPS	Crated Weight (lbs.)	L x D* x H† (inches)
PUR-48-D2R(L)-FB-N	1	2	11.1	1	1/6	6.5	259	48 1/4 x 30 x 30

Model : PUR-48-D2R(L)-FB-N

ELECTRICAL DATA	
Voltage	115/60/1
Plug Type	 NEMA 5-15P
Full Load Amperes	6.5
Compressor HP	1/6
Cord Length (ft.)	10
Refrigerant	R-290
DIMENSIONAL DATA	
Net Capacity (cu. ft.)	11.1
Ext. Length Overall (in.)	48 1/4 (1225mm)
Ext. Depth Overall (in.)*	30 (762mm)
Ext. Height Overall (in.)†	30 (761mm)
# of Doors	1
# of Drawers	2
# of Shelves	1
Shelf Size (L x D) (in.)	21 x 17
Net Weight (lbs.)	240
Gross Weight (lbs.)	259

Design and specifications subject to change without notice.
Actual shipping weight may differ due to extra packing materials for product protection.
* Depth does not include 7/8" for drawer handles.
† Height does not include 5-1/8" for caster height.

■ **WARRANTY : 5 Year Parts and Labor Warranty
7 Year Compressor Warranty**

■ **STANDARD FEATURES**

- **Anti-corrosion coated evaporator**
- **Self-contained system**
- **4" dia. swivel casters with locks on the front set**

■ **OPTIONAL ACCESSORIES**

- 1" caster, 1/2" diameter & 13 TPI: S28R813660 (non-brake)
- 2.5" caster, 1/2" diameter & 13 TPI: 30265H0100 (non-brake), 30265H0200 (w/ brake)
- 5" caster, 1/2" diameter & 13 TPI: M726500100 (non-brake), M726500200 (w/ brake)
- Leveling leg, 1/2" - 13 TPI x 1.54": LFM1213566
- 6" ABS plastic leg: 30221M0200
- 6" stainless steel leg: 30221M0600
- Single overshef, stainless steel, 48-3/8" W: TSOS-4S

Ver.20230802

PLAN VIEW

(unit : inch)

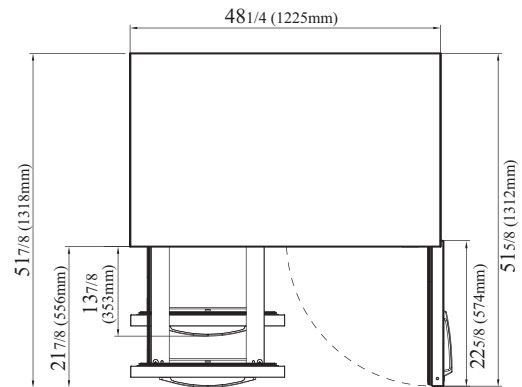

PUR-48-D2R-FB-N
TOP VIEW

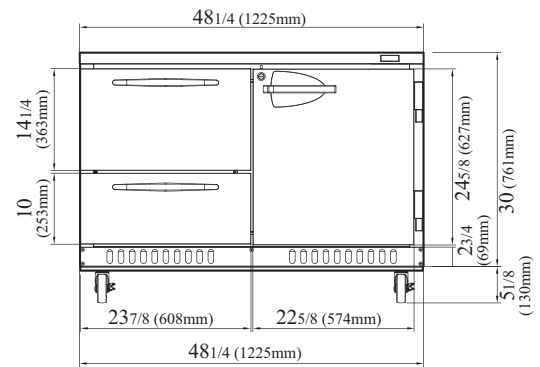

PUR-48-D2R-FB-N
FRONT VIEW

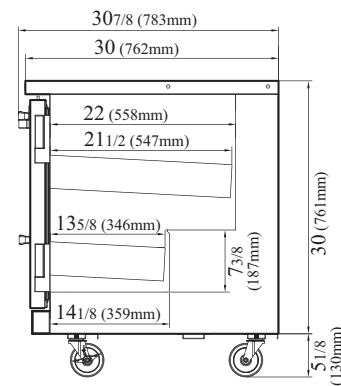

SIDE VIEW



- Turbo Air : 800-627-0032
- GK : 800-500-3519
- Warranty : 800-381-7770
- AC : 888-900-1002

