

**REFRIGERATOR MANUFACTURER**  
**Turbo air**  
 more durable, efficient, beautiful

4184 E. Conant St.  
 Long Beach, CA 90808  
 Tel. 310-900-1000  
 Fax. 310-900-1077  
[www.turboairinc.com](http://www.turboairinc.com)

Project:	
Model #:	
Item #:	
Available W/H:	Qty:
Approval:	
AIA #:	SIS #:
CSI Section 11400	

# Jumbo Glass Door Refrigerator

Swing Door Merchandisers  
 Super Deluxe Series

**TJMR-55SDW(B)-N**

## FEATURES & BENEFITS

### Self-Cleaning Condenser

The accumulation of dust in the condenser can cause the failure or breakdown of refrigerators. Refrigerators run normally until they reach a certain level of accumulation. At some point, when they are over the limit, their performance drops quickly resulting in damage to, or disposal of the stored products inside. The Self-Cleaning Condenser device keeps the condenser clean and prevents system failure by automatically brushing daily.

### Digital temperature control & monitor system

- Keeps food products safe by maintaining constant temperatures
- Alarms that sound when doors are not sealed shut; protect against food spoilage that originates from cold air leaks
- Early Warning Alarm program detects issues before malfunction occurs
- Digital display allows for easy monitoring
- Programs interpret the condition of refrigeration systems by self-diagnosis
- Rapid cool-down function (Turbo Cooling)
- Automatic evaporator fan motor delays

### Hydrocarbon refrigerants (R-290)

With innovative and eco-friendly technology, Turbo Air brings you hydrocarbon refrigerators designed to meet DOE's Energy Conservation Standards in 2017 and to use EPA's SNAP Program approved HC refrigerants. Hydrocarbon refrigerants do not deplete the ozone layer and have very low contribution to global warming (ODP-0, GWP-3).

### Energy conserving fan control

Utilizing algorithmic air circulation for optimal temperature levels, our innovative fan control system conserves energy by at least 15% and increases compressor life by up to 30%.

### Double pane glass doors with Low-E glass

Energy saving double pane glass doors are equipped with Low-emissivity glass, which reduces outer heat gain and decreases energy consumption. It enhances energy efficiency and minimizes condensation. Lightweight door construction also reduces door maintenance and bushing wear, which in turn facilitates smoother door opening.

### High-density polyurethane insulation

The entire cabinet structure is foamed-in-place using high density, CFC free polyurethane insulation.

### LED interior lighting

### Adjustable PE (polyethylene) coated wire shelves

### Refrigerator holds 33°F ~ 38°F for the best in food preservation

- All left hinged model standard
- All right hinged model available



TJMR-55SDW-N

TJMR-55SDB-N

### Patented Self-Cleaning Condenser

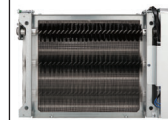

This product is equipped with a fine mesh filter to the front of the condenser to catch dust, and a rotating brush that moves up and down daily to remove excess buildup outward and away.

### Benefits over Remote Units

- Loading capacity is the same as an endless remote unit
- No plumbing required
- No installation work required
- Low maintenance expenses
- Energy saving
- Easy to relocate

NATURAL Refrigerant

SPFC ISO 9001:2008

ETL Intertek

ETL Intertek

5 YEAR WARRANTY

7 YEAR WARRANTY

ENERGY STAR Qualified

Model	Swing Doors	CU./FT.	#of Shelves	HP	AMPS	Crated Weight (lbs.)	L x D* x H (inches)
TJMR-55SDW(B)-N	2	62	12	2/5	5.0	756	65 1/8 x 38 x 83 1/2

# Jumbo Glass Door Refrigerator

Swing Door Merchandisers  
Super Deluxe Series

## Model : TJMR-55SDW(B)-N

ELECTRICAL DATA	
Voltage	115/60/1
Plug Type	 NEMA 5-15P
Full Load Amperes	5.0
Compressor HP	2/5
Cord Length (ft.)	8.5
Refrigerant	R-290
DIMENSIONAL DATA	
# of Doors	2
Net Capacity (cu. ft.)	62
Bottle Capacity (12 oz.)	1,848
Ext. Length Overall (in.)	65 1/8 (1654mm)
Ext. Depth Overall (in.)*	38 (965mm)
Ext. Height Overall (in.)	83 1/2 (2120mm)
Int. Length Overall (in.)	60 (1524mm)
Int. Depth Overall (in.)	33 1/8 (840mm)
Int. Height Overall (in.)	58 5/8 (1489mm)
# of Shelves	12
Shelf Size (L x D) (in.)	29 x 29
Net Weight (lbs.)	659
Gross Weight (lbs.)	756

Design and specifications subject to change without notice.  
Actual shipping weight may differ due to extra packing materials for product protection.  
\* Depth does not include 2-1/4" for door handle.

■ **WARRANTY : 5 Year Parts and Labor Warranty  
7 Year Compressor Warranty**

### ■ STANDARD FEATURES

- Anti-corrosion coated evaporator
- White and black colors come standard

\*\* Lead time applies. Please contact your sales representative for more details to order.

## PLAN VIEW

(unit : inch)

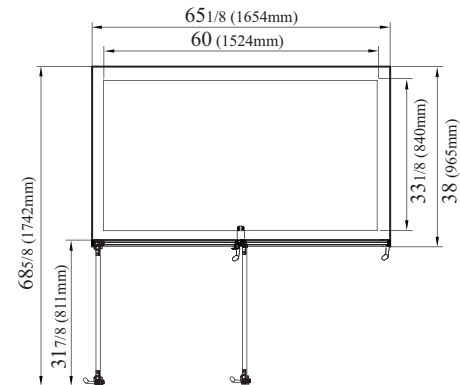

TOP VIEW

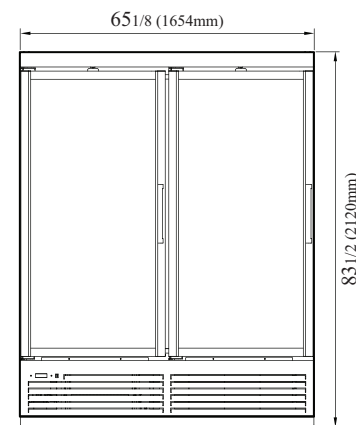

FRONT VIEW

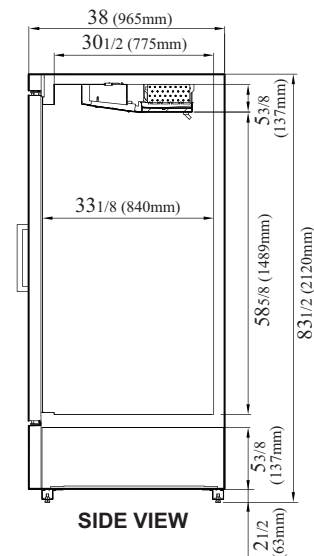

SIDE VIEW

Ver.20230103



■ Turbo Air : 800-627-0032 ■ GK : 800-500-3519  
■ Warranty : 800-381-7770 ■ AC : 888-900-1002



Continued product development may necessitate specification changes without notice.