

Project:	
Model #:	
Item #:	
Available W/H:	Qty:
Approval:	
AIA #:	SIS #:
CSI Section 11400	

Mega-Top Prep Table+Work Station - Slide Back Lid

Food Prep Tables
 Super Deluxe Series

FEATURES & BENEFITS

Self-Cleaning Condenser

The accumulation of dust in the condenser can cause the failure or breakdown of refrigerators. Refrigerators run normally until they reach a certain level of accumulation. At some point, when they are over the limit, their performance drops quickly resulting in damage to, or disposal of the stored products inside. The Self-Cleaning Condenser device keeps the condenser clean and prevents system failure by automatically brushing daily.

Digital temperature control & monitor system

Keeps food products safe by maintaining constant temperatures. External digital display allows for easy monitoring.

Hydrocarbon refrigerants (R-290)

With innovative and eco-friendly technology, Turbo Air brings you hydrocarbon refrigerators designed to meet DOE's Energy Conservation Standards in 2017 and to use EPA's SNAP Program approved HC refrigerants. Hydrocarbon refrigerants do not deplete the ozone layer and have very low contribution to global warming (ODP-0, GWP-3).

Cold Bunker system

Our innovative forced air system allows cold air to flow all around the food pan area, covering not only underneath the pan, but also the front, top and the rear. This unique air flow creates a cold air-shield around the pan, which maintains the food temperature at under 41°F (NSF requirement) even when the lids are opened. In addition, the compartment isolates pans from the reach-in area to prevent food spillage.

LED interior lighting & fan control

Energy efficient LED lighting lights every corner, making items easy to find. Fan control function automatically shuts off the fan when the door is open, which prevents hot air from being drawn in, thus maintaining the cool inner temperature.

High-density polyurethane insulation

The entire cabinet structure and solid doors are foamed-in-place high density, CFC free polyurethane insulation.

Stainless steel cabinet construction

The Turbo Air Super Deluxe model boasts a stainless steel interior (ABS door liner) and exterior (galvanized steel back & bottom). It guarantees the utmost in cleanliness and long product life. The Super Deluxe adds a touch of style to the most refined setting.

Sturdy, clean stainless steel shelving

Shelves are the most important part of cleanliness as they come in direct contact with food. After a while, PVC coated wire shelves may peel, rust and lead to unsanitary conditions. Only the Turbo Air Super Deluxe series uniquely provides stainless steel shelving.

Removable insulated slide-back lid

Removable hood and slide-back lid are easy to clean while providing a better view of the top opening.

9-1/2" deep, 1/2" thick high-density Polyethylene cutting board included with convenient side rail

Model : TST-60SD-12M-N-SL TST-60SD-12M-N-SL-LW



Removable cover with slide back lid



TST-60SD-12M-N-SL



TST-60SD-12M-N-SL-LW

Patented Self-Cleaning Condenser

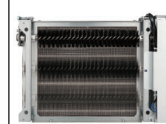

This product is equipped with a fine mesh filter to the front of the condenser to catch dust, and a rotating brush that moves up and down daily to remove excess buildup outward and away.

Refrigerator holds 33°F ~ 39°F for the best in food preservation

- TST-60SD-12M-N-SL: Right side work station
- TST-60SD-12M-N-SL-LW: Left side work station



Model	Swing Doors	CU./FT.	#of Shelves	#of Pans	HP	AMPS	Crated Weight (lbs.)	L x D x H† (inches)
TST-60SD-12M-N-SL(-LW)	2	19	2	12	1/5	8.9	322	60 1/4 x 34 x 39

Model : TST-60SD-12M-N-SL(LW)

ELECTRICAL DATA	
Voltage	115/60/1
Plug Type	 NEMA 5-15P
Full Load Amperes	8.9
Compressor HP	1/5
Cord Length (ft.)	10
Refrigerant	R-290
DIMENSIONAL DATA	
Ext. Length Overall (in.)	60 1/4 (1530mm)
Ext. Depth Overall (in.)*	34 (864mm)
Ext. Height Overall (in.)†	39 (992mm)
# of Doors	2
# of Shelves	2
# of Pans	12
# of Hood	1
Net Capacity (cu. ft.)	19
Shelf Size (L x D) (in.)	27 x 17
Net Weight (lbs.)	290
Gross Weight (lbs.)	322

Design and specifications subject to change without notice.
Actual shipping weight may differ due to extra packing materials for product protection.
* Depth does not include 3" for cutting board and 1" for rear spacers.
† Height does not include 5" for caster height.

■ WARRANTY : 5 Year Parts and Labor Warranty 7 Compressor Year Warranty

■ STANDARD FEATURES

- Anti-corrosion coated evaporator
- Self-contained system
- 4" dia. swivel casters with locks on the front set
- 1/6 size, 4" deep condiment pans included

* Accommodates 1/6 size, 6" deep condiment pans

** Lead time applies. Please contact your sales representative for more details to order.

■ OPTIONAL ACCESSORIES

- 1" caster, 1/2" diameter & 13 TPI: S28R813660 (non-brake)
- 2.5" caster, 1/2" diameter & 13 TPI: 30265H0100 (non-brake), 30265H0200 (w/ brake)
- 5" caster, 1/2" diameter & 13 TPI: M726500100 (non-brake), M726500200 (w/ brake)
- Leveling leg, 1/2" - 13 TPI x 1.54": LFM1213566
- 6" ABS plastic leg: 30221M0200
- 6" stainless steel leg: 30221M0600
- Additional stainless steel shelf: M607800100
- Single overshelf, stainless steel, 60-3/8" W: TSOS-5S
- Double overshelf, stainless steel, 60-3/8" W: TSOS-5R-T
- Door lock: lead time applies. Please contact your sales representative for more details to order.

Ver.20230815

PLAN VIEW

(unit : inch)

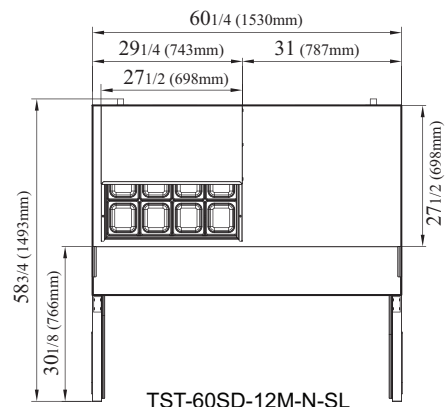

TOP VIEW

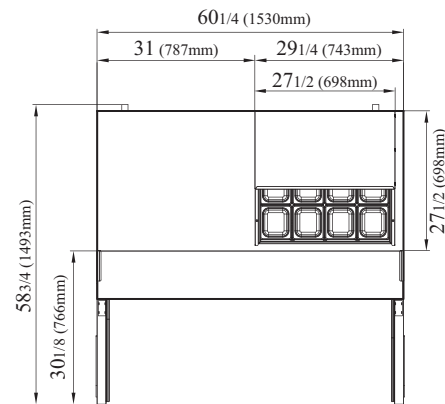

TOP VIEW

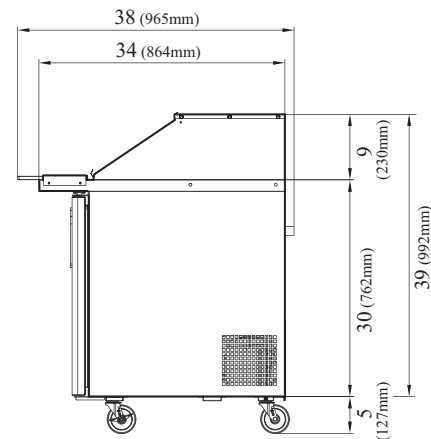

SIDE VIEW



- Turbo Air : 800-627-0032
- GK : 800-500-3519
- Warranty : 800-381-7770
- AC : 888-900-1002

TURBO AIR REFRIGERATOR MANUFACTURER

GERMAN KNIFE

RADIANCE

TURBO AIR REFRIGERATION SYSTEM

TEXAKING