

## Product Specifications Undercounter Freezers

CFZ552: 2 Door Undercounter Freezer  
 CFZ570: 3 Door Undercounter Freezer  
 CFZ588: 4 Door Undercounter Freezer



CFZ552



CFZ570



CFZ588

### Features and Specifications

CFZ552: volume of 9.88 cu ft, 2 epoxy coated shelves

CFZ570: volume of 15.57 cu ft, 3 epoxy coated shelves

CFZ588: volume of 21.2 cu ft, 4 epoxy coated shelves

Max weight per shelf: 66 lb

AISI 304 stainless steel interior and exterior

Temperature range: -13°F to 14°F

Electronic Control

Autodefrost

Epoxy coated, sealed evaporator eliminates potential corrosion

CFC-free high density polyurethane insulated cabinet

Factory pre-wired for dedicated outlet, 11 ft cord and plug included NEMA 5-15P

CFZ552 dimensions: 33" H x 57 <sup>15</sup>/<sub>32</sub>" W x 27 <sup>9</sup>/<sub>16</sub>" D

CFZ570 dimensions: 33" H x 76 <sup>37</sup>/<sub>64</sub>" W x 27 <sup>9</sup>/<sub>16</sub>" D

CFZ588 dimensions: 33" H x 95 <sup>43</sup>/<sub>64</sub>" W x 27 <sup>9</sup>/<sub>16</sub>" D

Environmentally friendly R449a refrigerant	CFZ552: 8.1 oz (0.230 kg)	CFZ570: 14.1 oz (0.400 kg)	CFZ588: 14.1 oz (0.400 kg)
--	---------------------------	----------------------------	----------------------------

### Model Details

Model	Description	Voltage/Hz/Phase/Amps	Shipping Weight
UCFZ552-SS61A	2 Door Undercounter Freezer	115 / 60 / 1 / 5	353 lb
UCFZ570-SS61A	3 Door Undercounter Freezer	115 / 60 / 1 / 5	507 lb
UCFZ588-SS61A	4 Door Undercounter Freezer	115 / 60 / 1 / 5	551 lb



**Product Specifications • Undercounter Freezers**

**Front (CFZ552)**

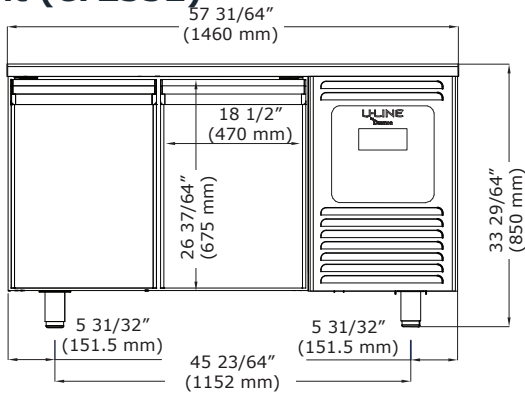

**Top**

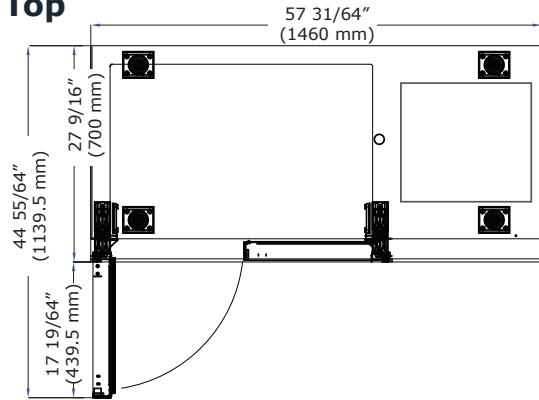

**Front (CFZ570)**

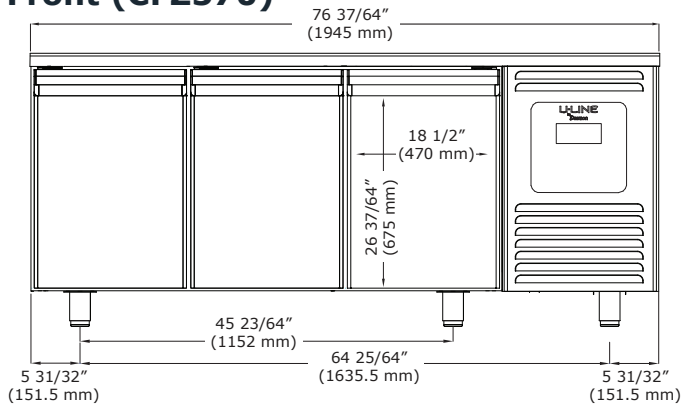

**Top**

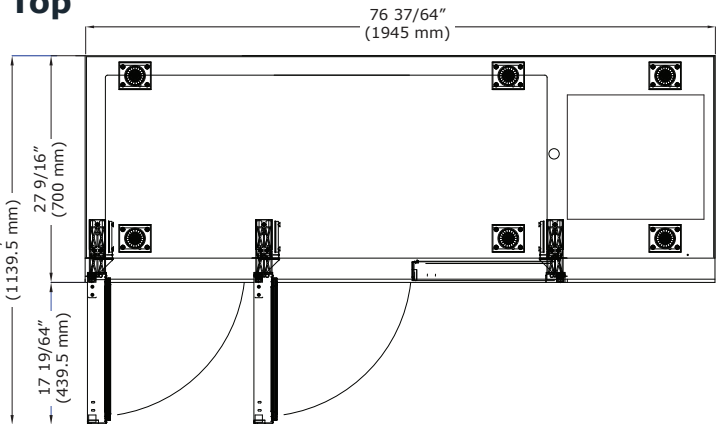

**Front (CFZ588)**

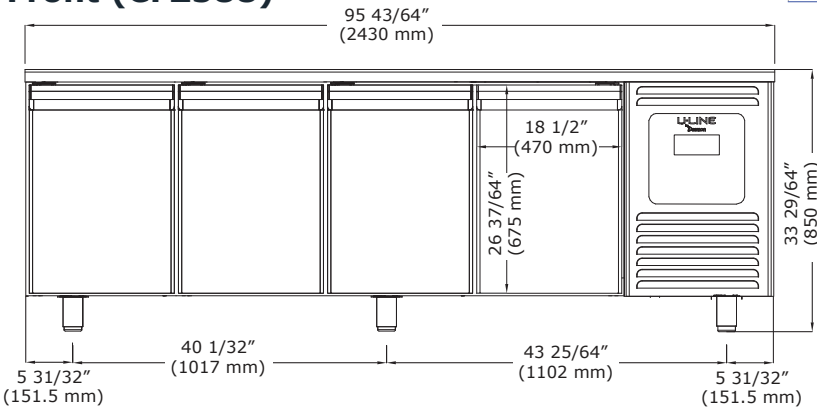

**Top**

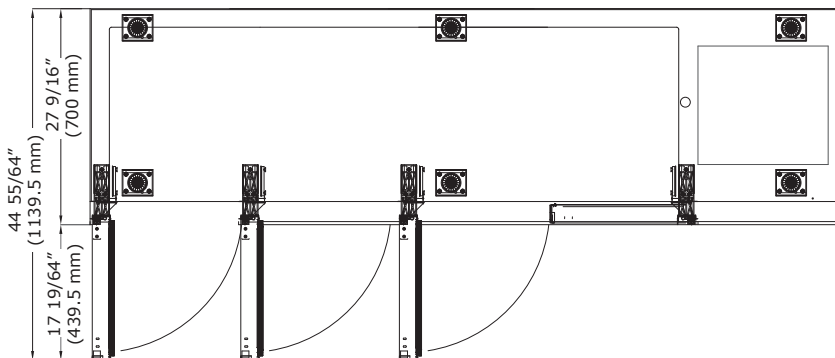

**Side (all models)**

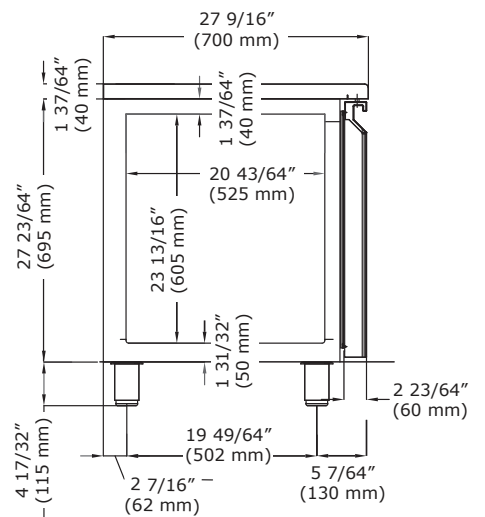

**Commercial Warranty**

1 Year (parts & labor) /  
5 year sealed system (parts)  
See complete warranty for details

