

72 cu ft Freezers, Reach-In

CFZ585-SS: Solid Door Freezer, Reach-In

CFZ585-SG: Glass Door Freezer, Reach-In



CFZ585-SS



CFZ585-SG

Features and Specifications

Volume of 72 cu ft
AISI 304 stainless steel interior and exterior with locks
Temperature range: -13°F to 14°F
Electronic digital temperature control with alarms
Autodefrost
High efficiency compressor with 20 running amps
High efficiency evaporator coil & condenser
Self-lubricating, sealed cast iron evaporator fan motor with high volume air flow design
Removable magnetic gasket for easy cleaning
CFC-free high-density polyurethane insulated cabinet
Factory pre-wired for dedicated outlet, 11 ft. cord and plug included NEMA 5-20P
Environmentally friendly R290 refrigerant - 2 x 3.5 oz (2 x 0.100kg)
3 sections, includes 9 epoxy coated wire shelves
Dimensions: 83 15/32" H x 85 3/64" W x 31 15/32" D
LED lighting
8 Adjustable stainless steel legs

Model Details

Model	Description	Voltage/Hz	Shipping Weight
UCFZ585-SS71A	72 cu ft Freezer Solid Door, Reach-In	115v / 60hz	650 lb
UCFZ585-SG71A	72 cu ft Freezer Glass Door, Reach-In	115v / 60hz	750 lb

Accessories

Model	Description	Shipping Weight
ULA4080584	Shelf Guide	.88 lb
ULAQ32-0002	Epoxy Coated Wire Shelf (20.86" x 25.6")	2.2 lb
ULA89010360	Caster Kit (8 casters, 2 with brakes)	13.22 lb



Product Specifications • 72 cu ft Freezers, Reach-In

Front (Closed - Solid Door)

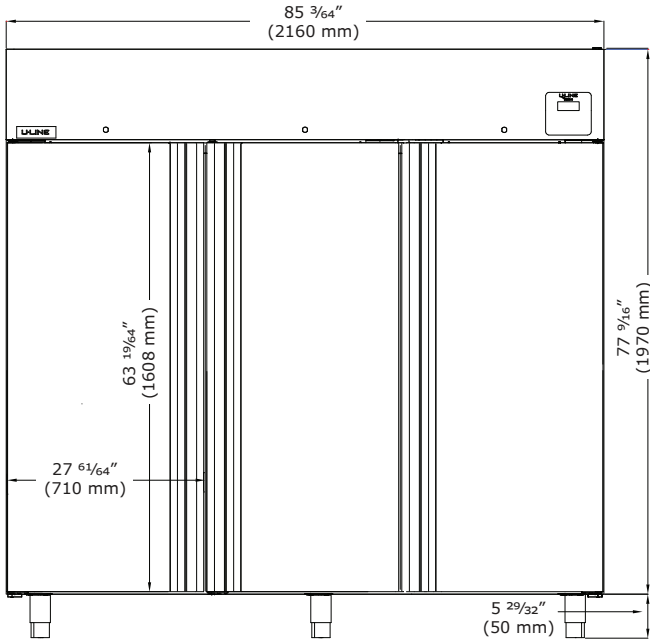

Front (Open)

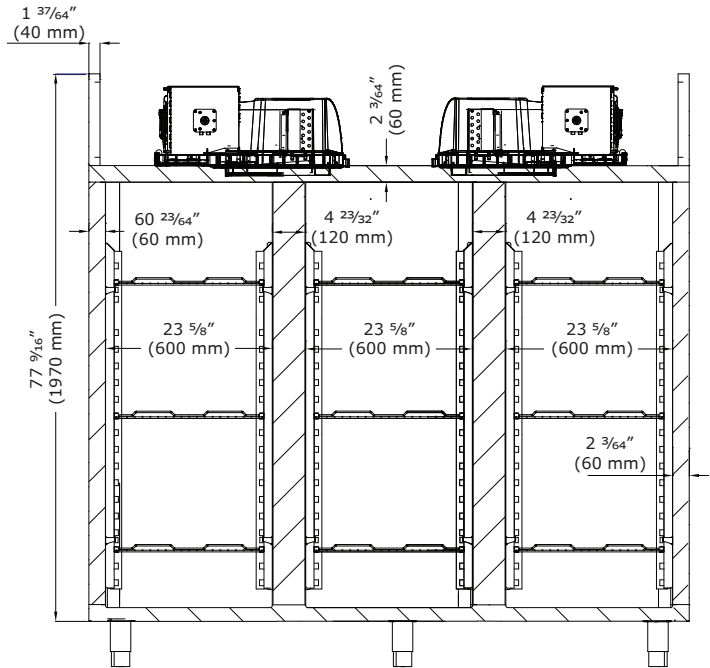

Front (Closed - Glass Door)

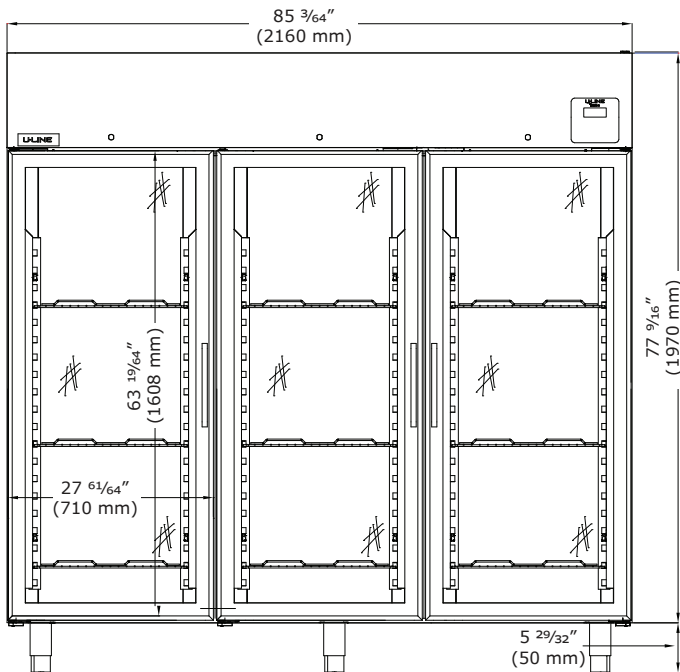

Side

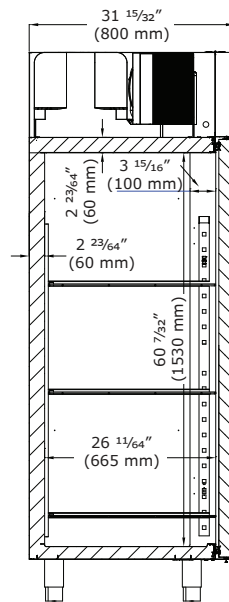

Top

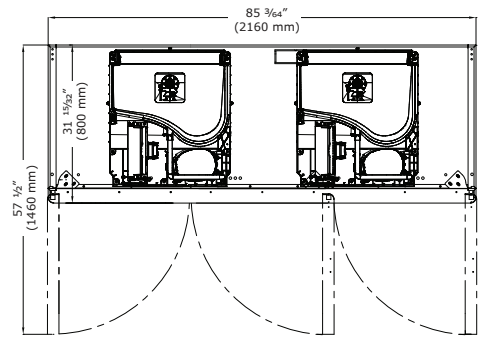

Commercial Warranty

1 Year (parts & labor) / 5 year sealed system (parts)
See complete warranty for details

