

Refrigerated Pizza Prep-Table

CPP466: 65" 2 Door Refrigerated Pizza Prep Table

CPP488: 88" 3 Door Refrigerated Pizza Prep Table



CPP466



CPP488

Features and Specifications

CPP466: volume of 14 cu ft	CPP488: volume of 21.89 cu ft	
AISI 304 stainless steel interior and exterior with granite worktop, ETL sanitation certified		
Temperature range: 28°F to 46°F		
Electronic digital temperature control with alarms		
Autodefrost		
High efficiency compressor, side mount, with 5 running amps		
Epoxy coated, sealed evaporator eliminates potential corrosion		
Self-lubricating, sealed cast iron evaporator fan motor with high volume airflow design		
Interior rounded corners for easy cleaning		
CFC-free high-density polyurethane insulated cabinet		
Factory pre-wired for dedicated outlet, 11 ft cord and plug included NEMA 5-15P		
Environmentally friendly R449a refrigerant	CPP466: 10.6 oz (0.280 kg)	CPP488: 17.5 oz (0.500 kg)
CPP466 includes 2 epoxy coated wire shelves	CPP488 includes 3 epoxy coated wire shelves	
CPP466 Dimensions: 40 5/16" H x 65 1/8" W x 31 15/32" D	CPP488 Dimensions: 40 5/16" H x 88 3/8" W x 31 15/32" D	

Model Details

Model	Description	Voltage/Hz/Phase	Shipping Weight
UCPP466-SS61A	65" 2 Door Refrigerated Pizza Prep Table	115v / 60hz / 1	662 lb
UCPP488-SS61A	88" 3 Door Refrigerated Pizza Prep Table	115v / 60hz / 1	882 lb

Accessories

Model	Description	Shipping Weight
ULA4082514	Shelf Guide	.88 lb
ULAQ32-4666-ETL	Epoxy Coated Wire Shelf	2.2 lb
ULAGN-1315-T	Stainless GN 1/3 Pan (6.93" x 12.79" x 5.9")	1.67 lb
ULAGNC-13	Stainless GN 1/3 Pan Top (6.93" x 12.79")	.77 lb
ULAGN-1615	Stainless GN 1/6 Pan (6.93" x 6.37" x 5.9")	.88 lb
ULAGNC-16	Stainless GN 1/6 Pan Top (6.93" x 6.37")	.77 lb
ULAGN-2815	Stainless GN 2/8 Pan (UCPP466 Only) (5.19" x 12.79" x 5.9")	1.3 lb
ULAGNC-28	Stainless GN 2/8 Pan top (UCPP466 Only) (5.19" x 12.79")	.77 lb



Product Specifications • Refrigerated Pizza Prep Table

Front (2 Door)

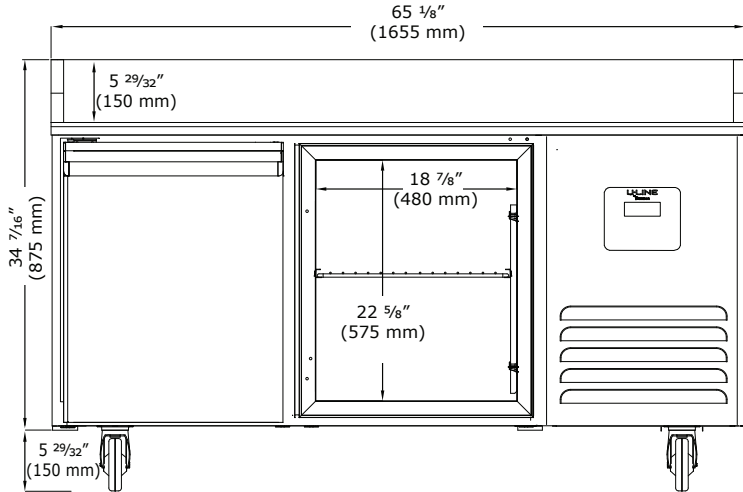

Side

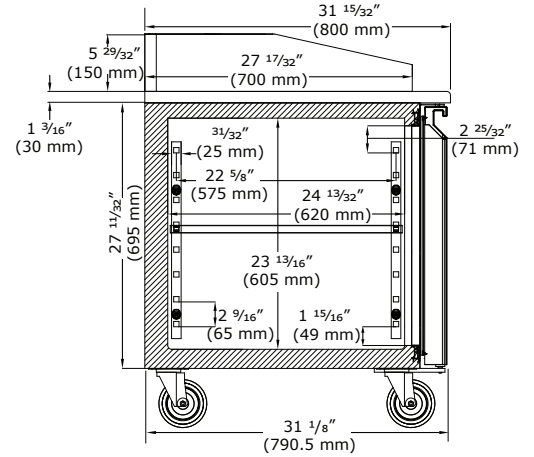

Front (3 Door)

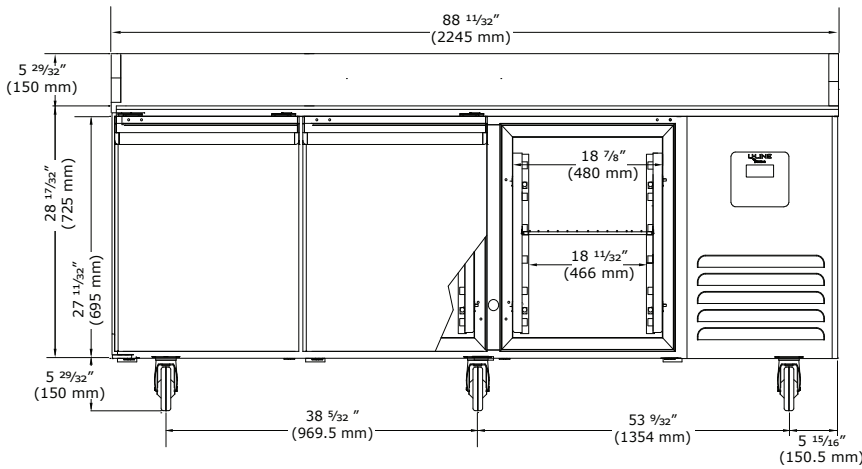

Top

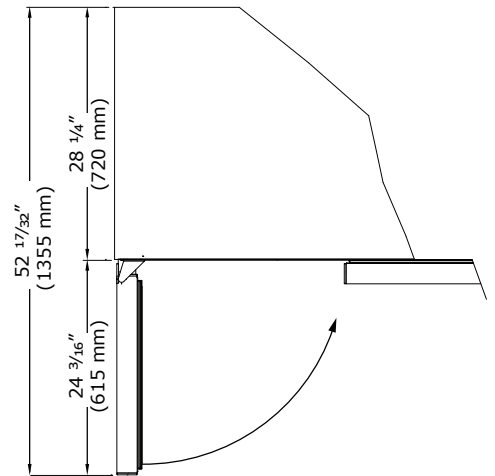

Commercial Warranty

1 Year (parts & labor) / 5 year sealed system (parts)
See complete warranty for details



Intertek