

74 cu ft Refrigerators, Reach-In

CRE585-SS: Solid Door Refrigerator, Reach-In

CRE585-SG: Glass Door Refrigerator, Reach-In



CRE585-SS



CRE585-SG

Features and Specifications

Volume of 74 cu ft
AISI 304 stainless steel interior and exterior with locks
Temperature range: 28°F to 46°F
Electronic digital temperature control with alarms
Autodefrost
High efficiency top-mounted compressor with 7 running amps
High efficiency evaporator coil & condenser
Epoxy coated, sealed evaporator eliminates potential corrosion
CFC-free high density polyurethane insulated cabinet
Factory pre-wired for dedicated outlet, 11 ft cord and plug included NEMA 5-15P
Environmentally friendly R290 refrigerant - 2 x 3.2 oz (2 x 0.090 kg)
3 sections, includes 9 epoxy coated wire shelves
Dimensions: 83 15/32" H x 85 3/64" W x 31 15/32" D
LED lighting
8 adjustable stainless steel legs

Model Details

Model	Description	Voltage/Hz	Shipping Weight
UCRE585-SS71A	Refrigerator, Reach-In, Solid Door	115v / 60hz	650 lb
UCRE585-SG71A	Refrigerator, Reach-In, Glass Door	115v / 60hz	750 lb

Accessories

Model	Description	Shipping Weight
ULA4080584	Shelf Guide	.88 lb
ULAQ32-0002	Epoxy Coated Wire Shelf (20.86" x 25.6")	2.2 lb
ULA89010360	Caster Kit	13.22 lb



Front (Closed - Solid Door)

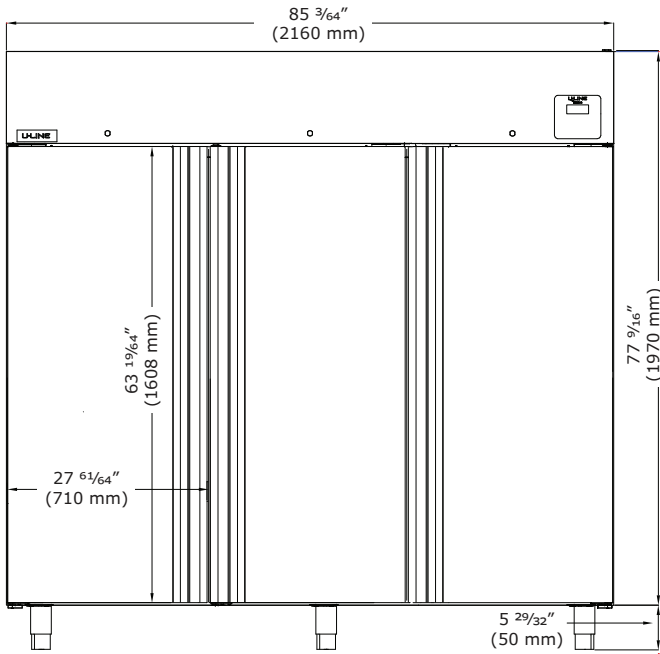

Front (Open)

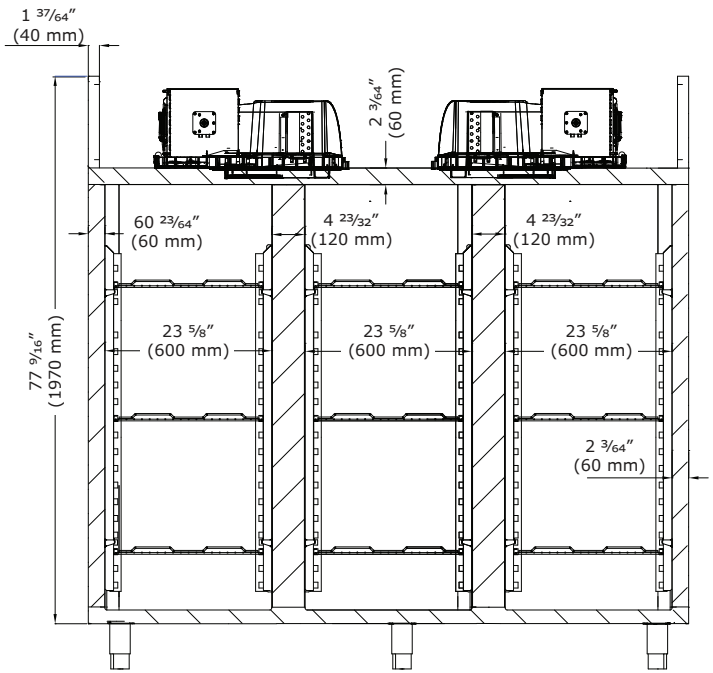

Front (Closed - Glass Door)

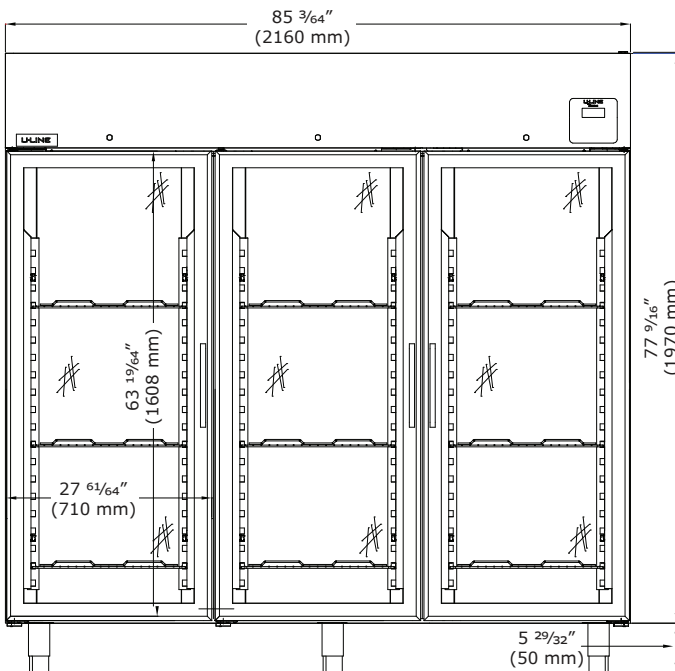

Side

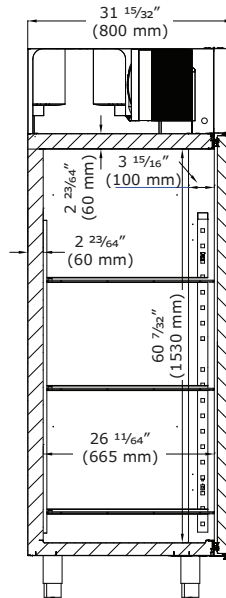

Top

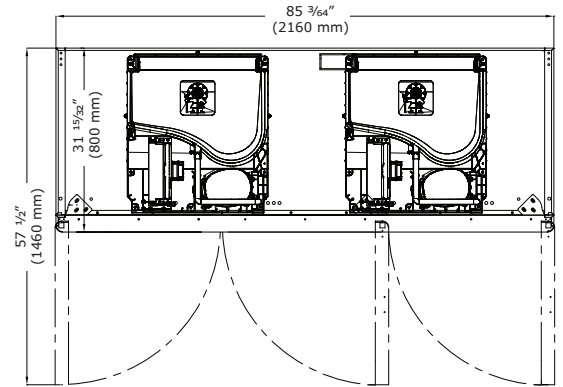

Commercial Warranty

1 Year (parts & labor) / 5 year sealed system (parts)
See complete warranty for details

