

Undercounter Refrigerators

- CRE552: 2 Door Undercounter Refrigerator
- CRE570: 3 Door Undercounter Refrigerator
- CRE588: 4 Door Undercounter Refrigerator



CRE552



CRE570



CRE588

Features and Specifications

CRE552: volume of 9.88 cu ft, 2 epoxy coated shelves			
CRE570: volume of 15.57 cu ft, 3 epoxy coated shelves			
CRE588: volume of 21.2 cu ft, 4 epoxy coated shelves			
Max weight per shelf: 66 lb			
AISI 304 stainless steel interior and exterior			
Temperature range: 28°F to 46°F			
Electronic Control			
Autodefrost			
Epoxy coated, sealed evaporator eliminates potential corrosion			
CFC-free high density polyurethane insulated cabinet			
Factory pre-wired for dedicated outlet, 11 ft cord and plug included NEMA 5-15P			
Environmentally friendly R449a refrigerant	CRE552: 41.1 oz (0.400 kg)	CRE570: 17.5 oz (0.500 kg)	CRE588: 17.5 oz (0.500 kg)
CRE552 dimensions: 33" H x 57 15/32" W x 27 9/16" D			
CRE570 dimensions: 33" H x 76 37/64" W x 27 9/16" D			
CRE588 dimensions: 33" H x 95 43/64" W x 27 9/16" D			

Model Details

Model	Description	Voltage/Hz/Phase/Amps	Shipping Weight
UCRE552-SS61A	2 Door Undercounter Refrigerator	115 / 60 / 1 / 5	353 lb
UCRE570-SS61A	3 Door Undercounter Refrigerator	115 / 60 / 1 / 5	507 lb
UCRE588-SS61A	4 Door Undercounter Refrigerator	115 / 60 / 1 / 5	551 lb



Product Specifications • Undercounter Refrigerators

Front (CRE552)

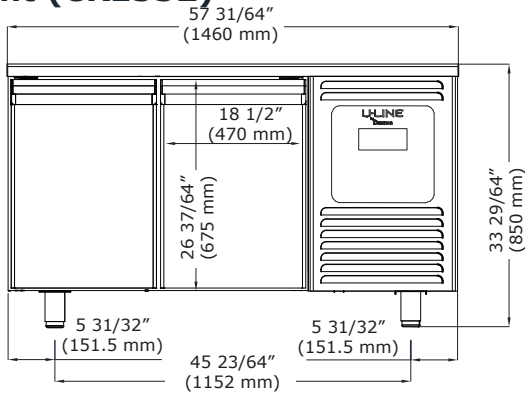

Top

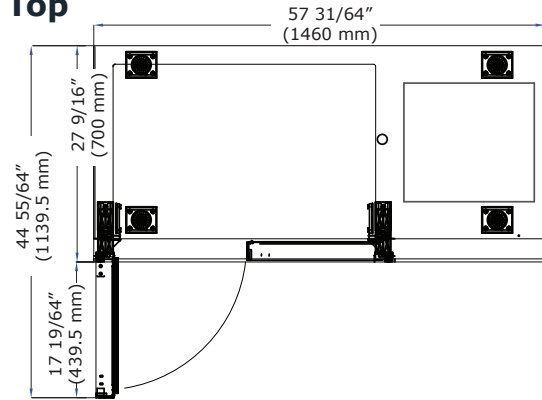

Front (CRE570)

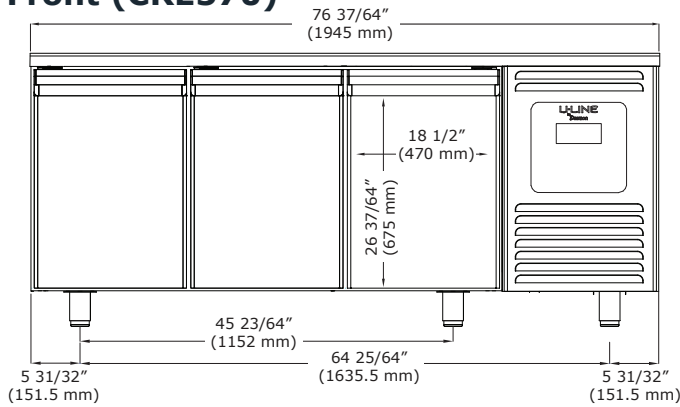

Top

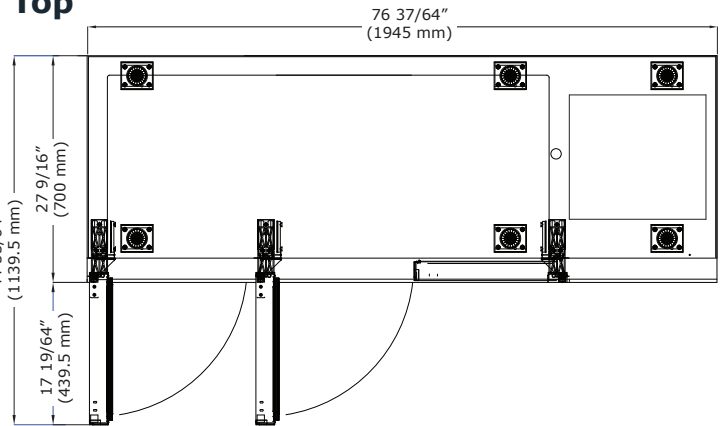

Front (CRE588)

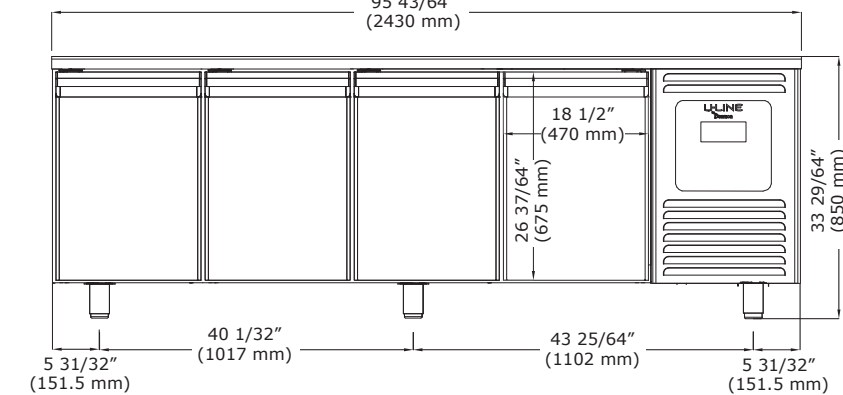

Side (all models)

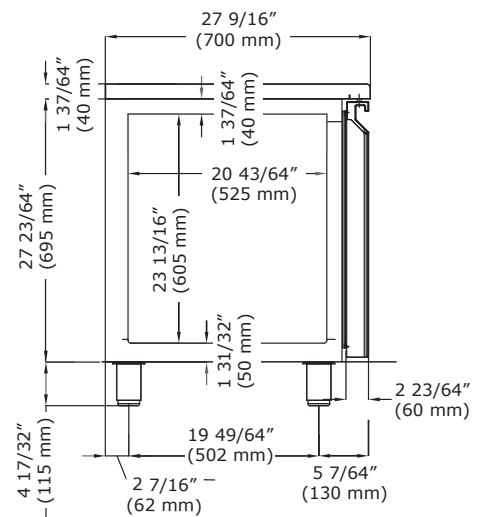

Top

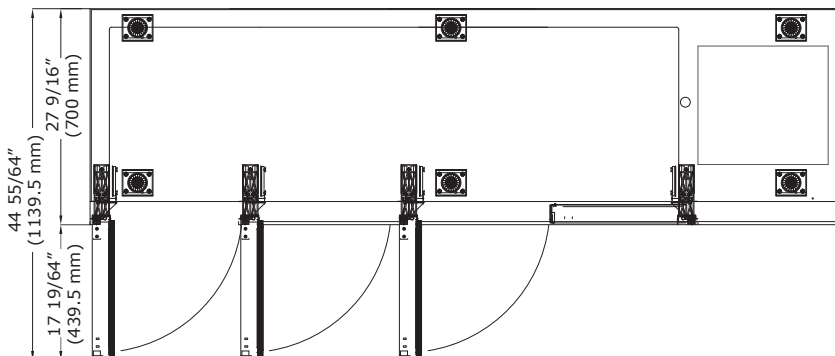

Commercial Warranty

1 Year (parts & labor) /
5 year sealed system (parts)
See complete warranty for details

