



Refrigeration Equipment Manufacturer

Undercounter Freezer

U2BFF-12S

Description: Two solid door undercounter freezer, 12 cu. ft

Features & Benefits

Stainless steel interior and exterior for greater durability, construction and appearance.

Self-contained **rear-mounted** compressor with high humidity coated **fin coil** evaporator.

- Holds -10° F to 5° F for freezer

2.5" thick, foamed-in-place polyurethane high density insulation.

Two adjustable, epoxy-coated steel wire shelves. 5" casters standard. **Easy mobility and installation.**

16 gauge, 300 series stainless steel top.

Heavy-duty overall construction for high-volume, constant duty operation.

Self-closing doors with 90 degree hold open feature and **fully-recessed handles.**

Electric condensate evaporator - **no floor drain required!**

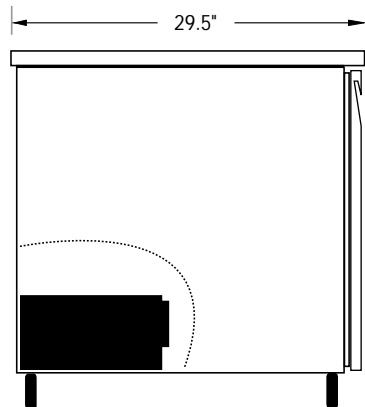

SIDE VIEW

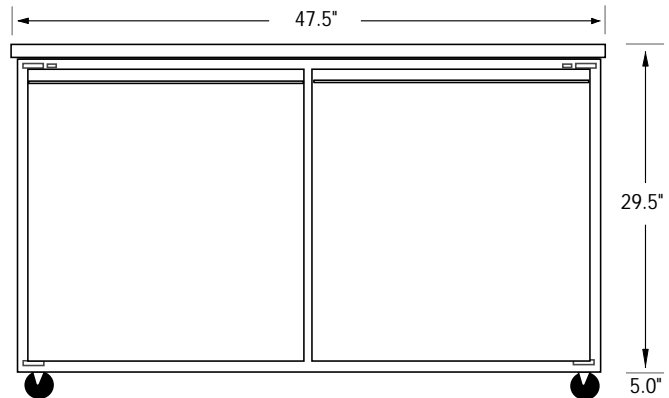

FRONT VIEW

Dimensions	W	D	H
Exterior (inches)	47.5	29.5	29.5
(height with casters)			34.5
Pallet size (inches)	49.5	31.5	4.5

General Information	Cubic Feet Shelves	
Freezer	12	2

Shelf size:	22" x 22"	Volts 115 Amps 6.10 (run) 12.20 (start)
Exterior:	Stainless	
Interior:	Stainless	
Unit Weight (lbs.)	230	
Gross weight (lbs.)	285	
Cord length (inches)	79	
Nema:	5-20p	

Compressor Information	# compressors	Refrigerant Capacity
Refrigerant R404A	1	Medium/Low Temp
Use	H.P	.
Freezer	1/2	

SPECIFICATIONS SUBJECT TO CHANGE WITHOUT NOTICE

TOP VIEW

