

Champion®

The Dishwashing Machine Specialists

Project _____

Item No. _____

Quantity _____

UH330B UNDERCOUNTER

STANDARD FEATURES

- Heat recovery: **Cold water feed only!**
Up to 50% more energy efficient!
Quicker drying of wares!
Condensation is removed!
Reduced operating costs!
- **“Dry Assist”** provides improved and quicker drying of wares.
- **“Vari-cycle,”** 3 cycle time options for enhanced cleaning
- Insulated panels and booster
- **Soft Start** protects glasses and dishes from chipping and breaking
- Simple field conversion from single to three phase
- Precise digital temperature display and control
- **ENERGY STAR®** Qualified
- **Rinse Sentry** – ensures 180°F/ 82°C final rinse for sanitized wares
- Standard liquid detergent and rinse-aid pumps
- Advanced service diagnostics
- Pumped drain
- Automatic drain cycle
- 1 HP corrosion resistant pump
- Independent stainless steel interchangeable upper and lower wash and rinse arms
- Includes two racks: 1 peg and 1 flat



UH330B Heat Recovery

Undercounter High Temperature Dishwashing Machine with Built-in Booster Heater



NEW MODEL

Photo is for general visual representation only. Please refer to specifications for the latest detailed product information.



SPECIFIER STATEMENT

Specified unit will be high temperature undercounter dishwasher operating on a 1/2" cold water supply only with heat recovery. Unit shall incorporate a “dry assist” feature to improve and speed-up the drying of wares.

Features selectable 150, 200 and 277 second cycle times, 3 time cycle options, LED temp display, Rinse Sentry, rinse aid and detergent pumps, flexible fill and drain hoses, stainless steel top and side panels. Constructed of stainless steel.

1 year parts and labor warranty.

OPTIONS & ACCESSORIES

- Additional Dish Racks**
 - Peg**
 - Flat**
- 17" Stand** Stainless Steel
- 6" Leg Stand**
- 3 Phase Connection** (prewired at factory)
- 1" Roller Kit** (includes 4 casters)
- Drain Water Tempering Kit** (0712382)
- Power Cord Kit**

Champion Industries, Inc.
3765 Champion Blvd, Winston-Salem, NC 27105
Tel: 336/661-1556 Fax: 336/661-1979
sales@championindustries.com
www.championindustries.com

2674 North Service Rd
Jordan Station, Ontario, Canada L0R 1S0
Tel: 800/263-5798 Fax: 905/562-5422
sales@moyerdiebellimited.com
www.championindustries.com/canada



UH330B Heat Recovery

Undercounter High Temperature
Dishwashing Machine with Built-in Booster Heater

Champion®

The Dishwashing Machine Specialists

Volume crated: **15 cu. ft./0.42 cu.m.**
Shipping weight crated: **215 lbs./97.5 kg.**

Dimensions shown in inches and [millimeters]

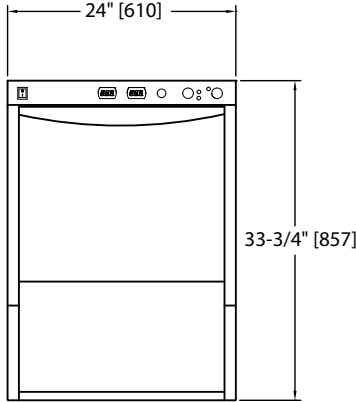

Front View

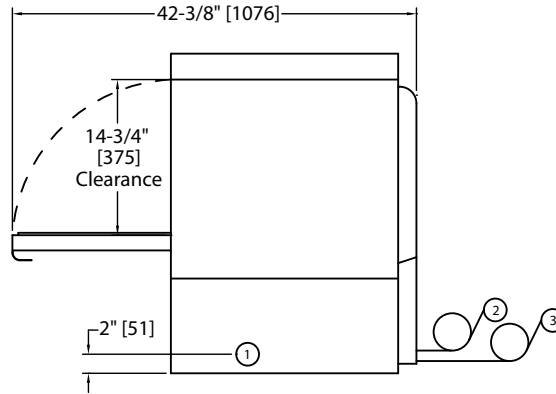

Side View

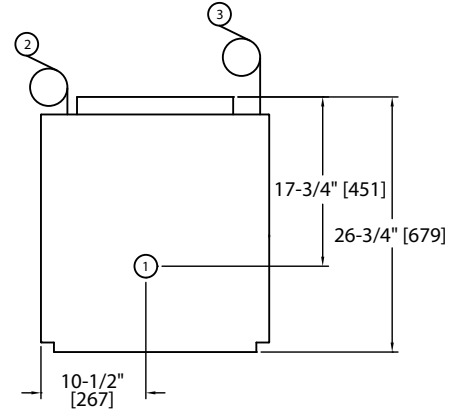

Plan View

Utilities

1 Electrical	208-240/60/1; 3 wire plus ground, (See Box). 208-240/60/3; 4 wire plus ground, (See Box). Field convertible to accept 3 phase power, see service manual for details
2 Cold Water	1/2" supply; 55-80°F [12-26°C] cold water; 25 PSI min. Machine equipped with 3/4" [19] hose connector.
3 Pumped Drain	5/8" [15.9] I.D. flexible reinforced hose, 6 ft. [1829] long. Max. drain flow 15 US gpm. [12.5 imp gal] Max. drain height 3 ft. [914]

UH330B with Booster

Elec. Specs.	Rated Amps	Minimum Supply Ckt. Conductor Ampacity	Maximum Overcurrent Protective Device
208/60/1	24	30	30
240/60/1	26	30	30
208/60/3	17	25	25
240/60/3	18	25	25

Field convertible to accept 3 phase power

Warning Plumbing and electrical connections should be made by qualified personnel who will observe all the applicable plumbing, sanitary and safety codes and the National Electrical Code.

Single Phase

Three Phase

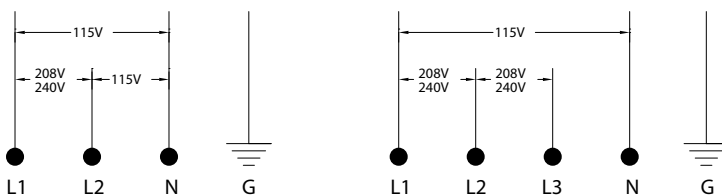

SPECIFICATIONS

Capacities

Cycle time (seconds)	150/200/277
Racks per hr.	24/18/13

Motor horsepower

Wash	1
------	---

Water consumption

U.S. Gal. (max. use) per hr.	15.2/12.7
U.S. Gal. per rack	0.76/0.63

Temperatures °F/°C

Wash	150/66
Rinse	180/82

Heating

Tank heat, electric, kW	2.0
Electric booster, kW	3.5

Time Cycle in Seconds

Wash	70/120/197
Rinse	20
Heat recovery/condense	55

Standard 20" x 20" [508 x 508]

Rack Complement

Dish	1
Open	1

Due to an ongoing value analysis program at Champion, specification contained in this catalog are subject to change without notice.